

FURUNO

OPERATOR'S MANUAL

SATELLITE COMPASS

MODEL SC-50



FURUNO ELECTRIC CO., LTD.
NISHINOMIYA, JAPAN



SAFETY INSTRUCTIONS

Safety Instructions for the Operator

⚠ WARNING

ELECTRICAL SHOCK HAZARD
Do not open the equipment.

 Only qualified personnel should work inside the equipment.

Do not disassemble or modify the equipment.

Fire, electrical shock or serious injury can result.

Immediately turn off the power at the switchboard if the equipment is emitting smoke or fire.

Continued use can cause fatal damage to the equipment. Contact a FURUNO agent for service.

Do not place liquid-filled containers on the top of the processor unit.

Fire or electrical shock may result if the liquid enters the equipment.

Use the proper fuse.

Use of a wrong fuse can damage the equipment and cause fire.

⚠ CAUTION

No one navigation device should ever be solely relied upon for the navigation of a vessel.

Always confirm position against all available aids to navigation (incl. nautical charts), for safety of vessel and crew.

Safety Instructions for the Installer

⚠ WARNING

Turn off the power at the switchboard before beginning the installation.

Fire or electrical shock can result if the power is left on.

Do not install the equipment where it may get wet from rain or water splash.

Water in the equipment can cause fire, electrical shock or damage to the equipment.



NOTICE

Observe the following compass safe distances to prevent interference to a magnetic compass:

	Standard Compass	Steering Compass
Display unit SC-502	0.5 m	0.3 m
Processor unit SC-501	1.3 m	0.8 m
Antenna unit SC-303	0.3 m	0.3 m
Antenna unit SC-603	0.3 m	0.3 m

WARNING LABEL
A warning label is attached to the processor unit. Do not remove the label. If the label is missing or damaged, contact a FURUNO agent or dealer about replacement.

⚠ WARNING ⚠
To avoid electrical shock, do not remove cover. No user-serviceable parts inside.

WARNING LABEL
Name: Warning Label (1)
Type: 86-003-1011-0
Code No.: 100-236-230

TABLE OF CONTENTS

FOREWORD	iv
SYSTEM CONFIGURATION	v
EQUIPMENT LIST	vi
1 PRINCIPLE OF OPERATION	1-1
2 INSTALLATION	2-1
2.1 Mounting Considerations.....	2-1
2.1.1 Antenna unit.....	2-1
2.1.2 Display unit, processor unit.....	2-3
2.2 Installing the Antenna Units	2-4
2.2.1 Antenna unit SC-303	2-4
2.2.2 Antenna unit SC-603	2-7
2.3 Installing the Processor Unit.....	2-12
2.3.1 Deck, bulkhead mount.....	2-12
2.3.2 Installation on the underside of a desk	2-13
2.4 Installing the Display Unit	2-14
2.4.1 Desktop, overhead mounting.....	2-14
2.4.2 Flush mount	2-14
2.5 Wiring.....	2-16
2.6 Initial Settings	2-19
2.6.1 Confirming satellite status; choosing mounting method.....	2-19
2.6.2 Choosing heading source.....	2-20
2.7 Connection of External Equipment.....	2-21
2.7.1 General wiring.....	2-21
2.7.2 Fabrication of cables.....	2-22
3 OPERATION	3-1
3.1 Controls.....	3-1
3.2 Turning the Power On/Off.....	3-2
3.3 Panel Illumination, Display Contrast.....	3-2
3.4 Choosing a Display.....	3-3
3.4.1 Description of displays.....	3-3
3.5 DGPS Alarm Setup.....	3-6
3.6 Confirming Satellite Status	3-7
3.7 GPS Setup.....	3-8
3.7.1 Displaying the GPS setup menu.....	3-8
3.7.2 GPS SETUP menu description.....	3-8
3.8 Output Data.....	3-9
3.8.1 Heading.....	3-9
3.8.2 Log pulse	3-12
3.9 System Setup	3-13
3.9.1 Geodetic data.....	3-13
3.9.2 Units of measurement.....	3-14
3.9.3 Using local time.....	3-14
3.9.4 Time format.....	3-14
3.9.5 Demonstration mode	3-15

3.10	WAAS/DGPS Setup	3-16
3.11	OTHERS Menu	3-19
3.12	TRIP Menu	3-20
3.13	Resetting Distance Run	3-21
4	MAINTENANCE, TROUBLESHOOTING	4-1
4.1	Preventive Maintenance	4-1
4.2	Troubleshooting	4-2
4.3	Diagnostics	4-3
4.4	Program Number	4-7
4.5	Clearing Data	4-7
4.6	Replacement of Battery	4-8
4.7	Replacement of Fuse	4-9
4.8	Error Messages	4-9
	APPENDIX	AP-1
	SPECIFICATIONS	SP-1
	INDEX	4-1

FOREWORD

A Word to the Owner of the SC-50

FURUNO Electric Company thanks you for purchasing the FURUNO SC-50 Satellite Compass. We are confident you will discover why the FURUNO name has become synonymous with quality and reliability.

For over 50 years FURUNO Electric Company has enjoyed an enviable reputation for quality and reliability throughout the world. This dedication to excellence is furthered by our extensive global network of agents and dealers.

Your satellite compass is designed and constructed to meet the rigorous demands of the marine environment. However, no machine can perform its intended function unless properly installed and maintained. Please carefully read and follow the operation, installation and maintenance procedures set forth in this manual.

We would appreciate feedback from you, the end-user, about whether we are achieving our purposes.

Thank you for considering and purchasing FURUNO.

Features

The SC-50 is a new satellite compass designed with FURUNO's advanced GPS kinematic technology. This compass finds a wide range of applications for any type of ships and mobile units at sea or on land.

The main features are

- Perfect for use as heading sensor for Radar/ARPA, AIS, ECDIS, scanning sonar, and video plotter
- There are no mechanical parts such as gimbals or rotating motor, thus the compass is free from routine maintenance
- The performance is not affected by geomagnetism thus it is suitable for use on any vessel
- No need for speed correction like a gyrocompass
- Short settling time - three minutes
- Meets the following requirements: IMO MSC. 116(73), ISO/FDIS 22090-3, IMO A. 694(17), IEC 60945 (2002-08), IEC 61162 (2000).

SYSTEM CONFIGURATION

The SC-50 consists of an antenna, a display unit and a processor unit. The tri-antenna system accommodates three antennas/receiver units and is available in a low-profile radome type or open type. The tri-antenna system helps reduce the influence of ship's motion (rolling).

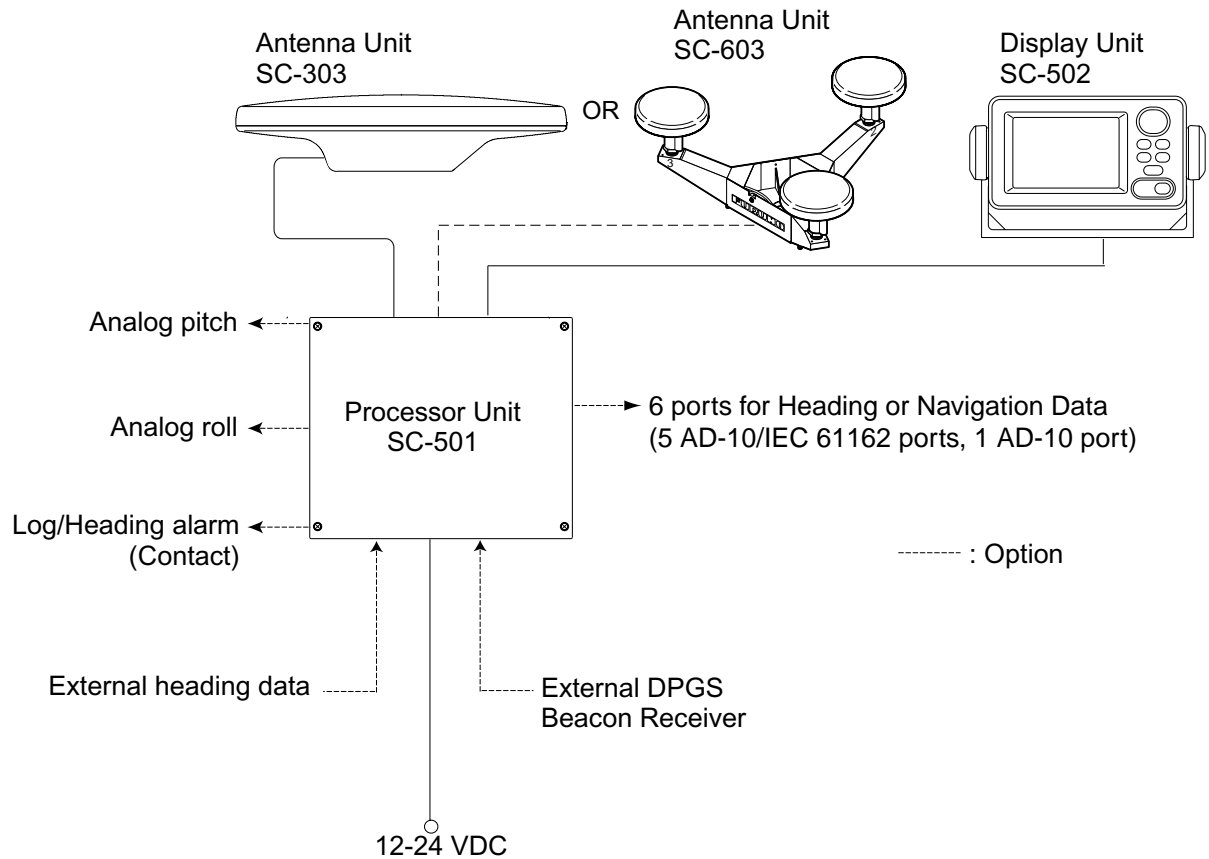

Category of Units

Processor Unit: Protected from weather

Display Unit: Protected from weather

Antenna Unit: Exposed to weather

System configuration

EQUIPMENT LIST

Standard supply

Name	Type	Code No.	Qty	Remarks
Antenna Unit	SC-303	—	Choose one	Radome type
	SC-603	—		Open type
Display Unit	SC-502	—	1	
Processor Unit	SC-501	—	1	
Installation Materials	CP20-02600	000-041-905	1	For antenna unit CP20-02601, MJ-A7SPF0006-100
	CP20-02203	004-380-660	1	For display unit Tapping screw (5X20, 4 pcs.)
Spare Parts	SP20-00901	004-377-600	1	For processor unit

Optional equipment

Name	Type	Code No.	Qty	Remarks	
Antenna Cable Set	CP20-01700	004-372-110	1	30 m	3 pcs., for antenna unit
	CP20-01710	004-372-120		50 m	
Antenna Cable	TPPX6-3D2V-15M	000-143-559	1		
Flush Mount F	OP20-29	000-041-405	1	For display unit	
Flush Mount S	OP20-17	000-040-720	1	For display unit	
Extension Cable	OP08-15-30	004-396-440	1	For DGPS, 30 m	
	OP08-15-60	004-396-450		For DGPS, 60 m	
Antenna Cable Set	OP08-17	004-392-510	1	For DGPS	

1 PRINCIPLE OF OPERATION

Own ship's heading can be determined by decoding the data in the carrier frequency in addition to ordinary GPS parameters. In principle, a pair of two antennas A1(ref) and A2(fore), each connected with an associated GPS engine and processor, are installed along the ship's fore-and-aft line. GPS systems at A1 and A2 calculate the range and azimuth to the satellite. Difference in range between A1 and A2 is $\Delta\lambda + n\lambda$ where λ is 19 cm. "n" is automatically found during the initialization stage by receiving three satellites. A fraction of a carrier wavelength, $\Delta\lambda$, is processed by FURUNO's advanced kinematic technology in geographical survey, thus determining a vector (range and orientation) A1 to A2.

In reality, a third antenna is used to reduce the influence of pitch, roll and yaw, and five satellites are processed to process 3D data. If the GPS signal is blocked by a tall building or the vessel is under a bridge, the 3-axis solid-state angular rate gyros in the processor unit take place of the satellite compass, maintaining the current heading continuously.

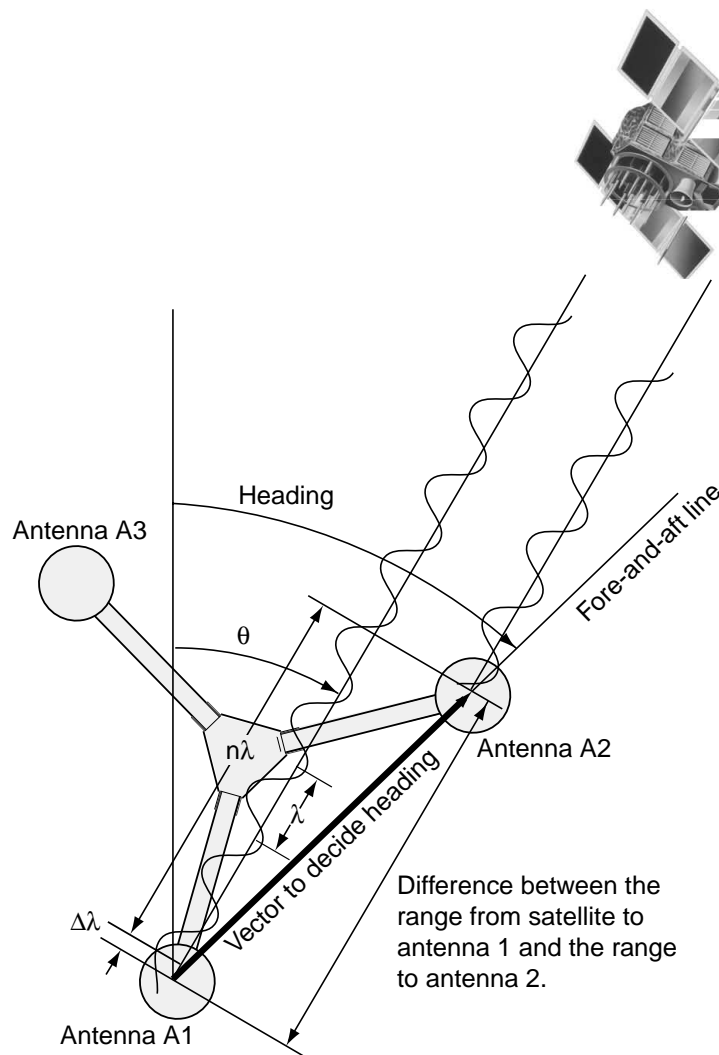

Principle of satellite compass operation

1 PRINCIPLE OF OPERATION

(This page intentionally left blank.)

2 INSTALLATION

2.1 Mounting Considerations

2.1.1 Antenna unit

General

- Keep the length of the antenna cable in mind when selecting a mounting location.

Installing the antenna above superstructures

- The antenna must be mounted above all other structures on the vessel to obtain an unobstructed view of the satellites regardless of vessel heading. Failure to do so will cause shadows and multipath reflection problems.

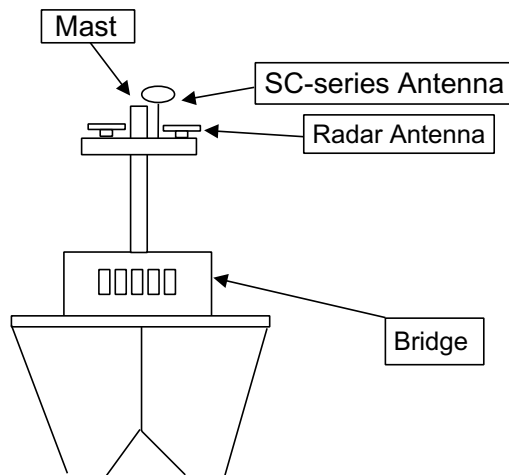

Example of antenna installed above all superstructures

Installing the antenna below superstructures

If it is not possible to mount the antenna above all superstructures on the vessel, as shown in the illustration above, shading and multipath problems may occur on at least one heading, and possibly more. To possibly avoid those problems, observe the guidelines in this section.

NOTICE

If the antenna is installed below any superstructure, the installation must be done over a two-day period, following the procedure in the service manual.

At least 12 hours are required to capture tracking data to measure multipath indexes and locate areas of shading.

2. INSTALLATION

- The horizontal separation between the antenna and masts must be as follows:

Mast diameter	Separation distance (minimum)
10 cm	1.5 m
30 cm	3 m

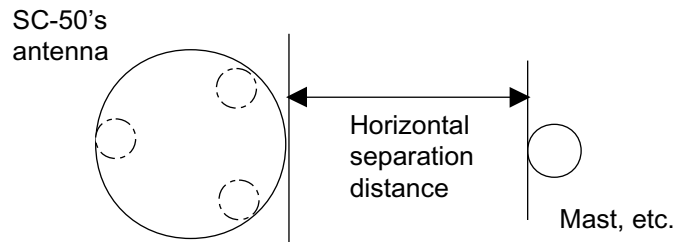

Horizontal separation between antenna and masts

- The field of view above the antenna should be as shown below, $\pm 80^\circ$ against zenith. To avoid reflections from masts and the like, locate the antenna well away from the shadows of the radar mast, etc.

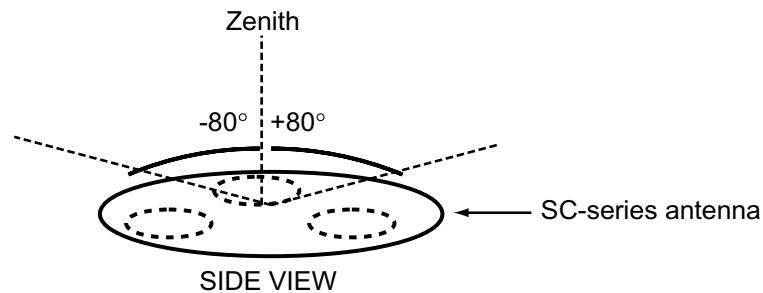

Antenna and field of view

- Referring to the illustration below, locate the antenna away from objects which might block reception, such as a mast.

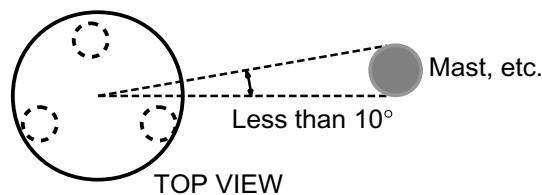

- Locate the antenna unit above the radar antenna, out of the radar beam.

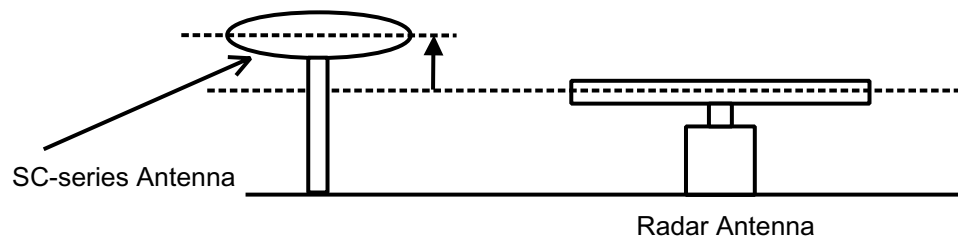

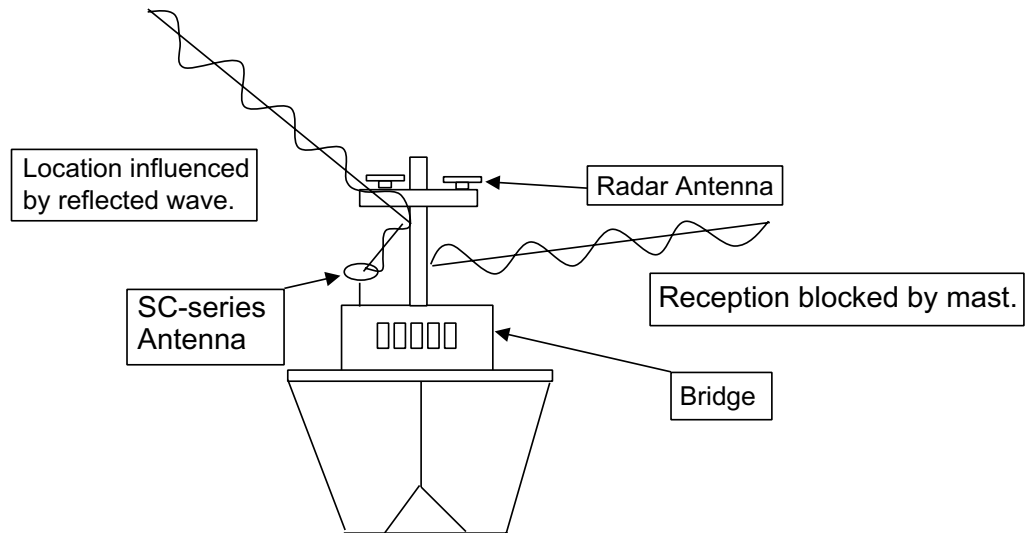

Example of antenna installed below superstructures

2.1.2 Display unit, processor unit

- Choose a location where vibration and shock are minimal.
- Install the units well away from locations subject to rain and water splash.
- Locate the units away from air conditioner vents.
- Keep the units out of direct sunlight because of heat that can build up inside their cabinets.
- Choose a well-ventilated location.
- For the display unit, choose a location where it can be easily operated.
- Leave sufficient space around the units to permit access for maintenance. See the outline drawing for recommended maintenance space.

2.2 Installing the Antenna Units

2.2.1 Antenna unit SC-303

Note: “Bird-repellent fixtures” may be attached to the antenna cover to prevent birds from alighting on the cover. If it is more convenient to attach them before fixing the antenna unit to the mounting location, do step 9 before fixing the antenna unit.

NOTICE

Fasten the antenna to the mounting location lastly if it is more convenient to connect the antenna cable before mounting the antenna unit.

1. Prepare a mounting platform (wood, steel or aluminum) in accordance with the illustration shown below. If corrosive material is used, take necessary anti-corrosion measures.

Note: When drilling holes in the platform, be sure they are parallel with the fore-and-aft line.

2. Fasten the antenna unit to the platform with four sets of M10 hex. bolts, spring washers and flat washers, orienting it as shown below. (The bow mark (△) on the antenna should face the bow.) The torque for the hex. bolts should be between 19.6-24.5 Nm.

NOTICE

Do not open the antenna.

This installation does not require removal of the antenna cover.

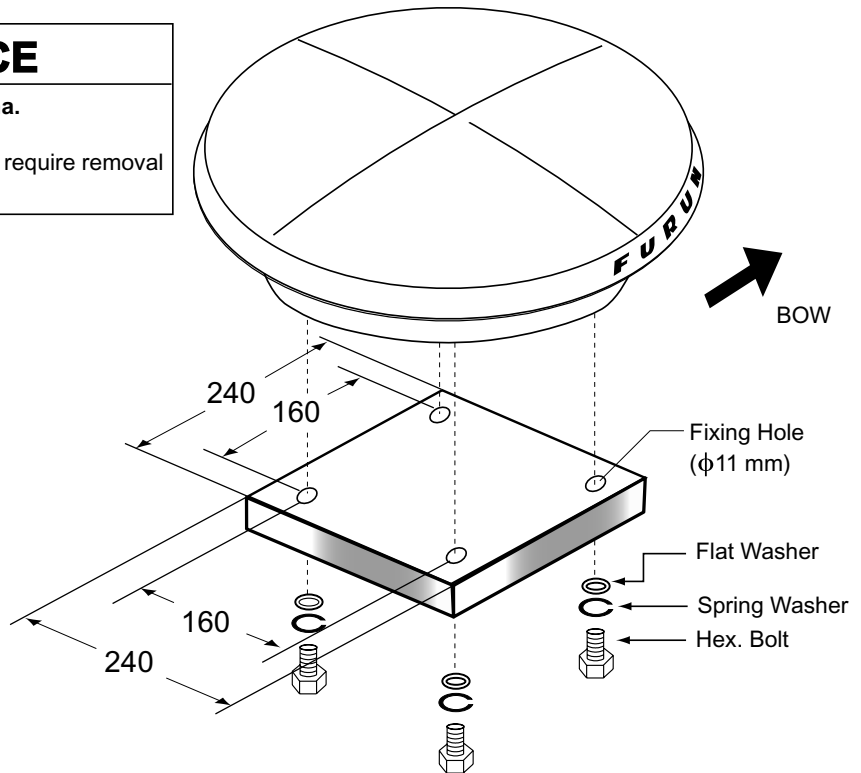

Mounting dimensions for antenna, orienting the antenna

3. Coat exposed parts of nuts, bolts and washers with silicone sealant.

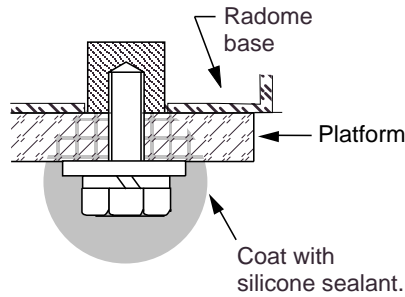

Coating bolt, nut and washers with silicone sealant

4. Connect the three coaxial cables coming from the antenna unit to the appropriate coaxial cables on the antenna cable, referring to the table below.

Cable from antenna (no. marked on cable)	Cable TTPX6-3D2V-15M
ANT 1	No color
ANT 2	Yellow
ANT 3	Red

5. Cover the antenna connectors with vulcanizing tape and vinyl tape, for waterproofing. Tie tape ends with a cable tie.

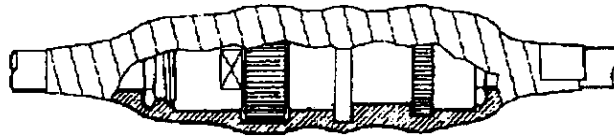

Waterproofing the antenna connector

6. Set the joints of the coaxial cables into the cavity in the antenna base.
7. Pass two cable ties (long life, temperature resistant type, local supply) through the hole shown in the figure below. Fasten them at the locations shown in the figure below.

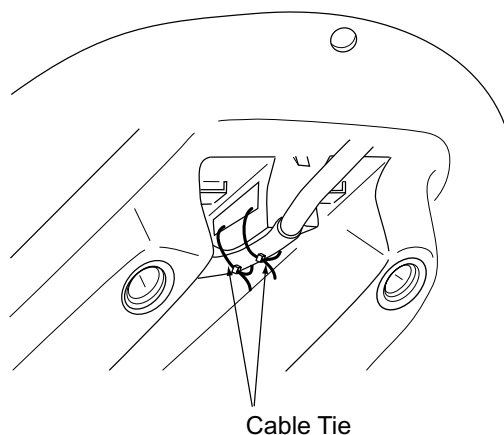

How to fasten the antenna cable

2 INSTALLATION

8. Set the “cable cover” to the antenna base as shown in the figure below.

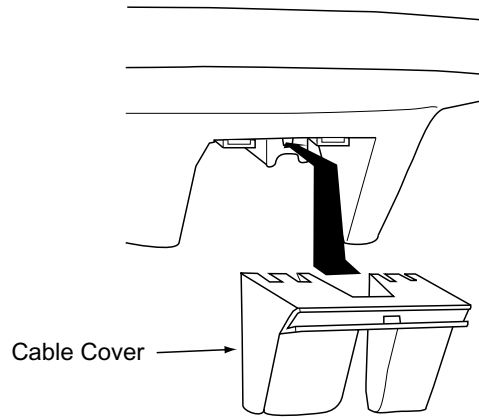

How to insert the cable cover

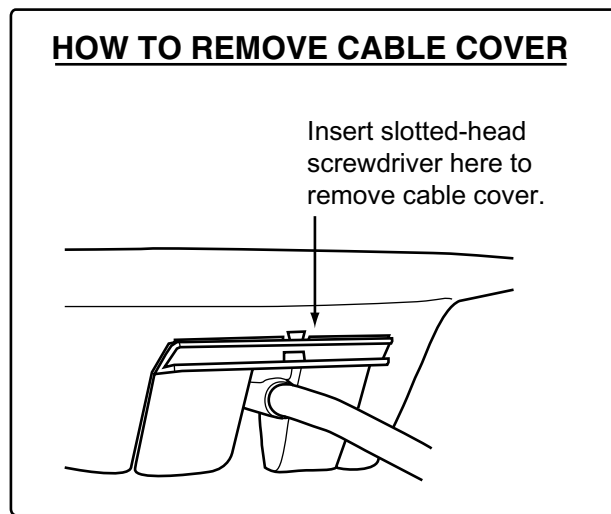

9. Attach nine “bird-repellent fixtures” (supplied) to the antenna cover as shown below. Use the paper pattern to position the fixtures.

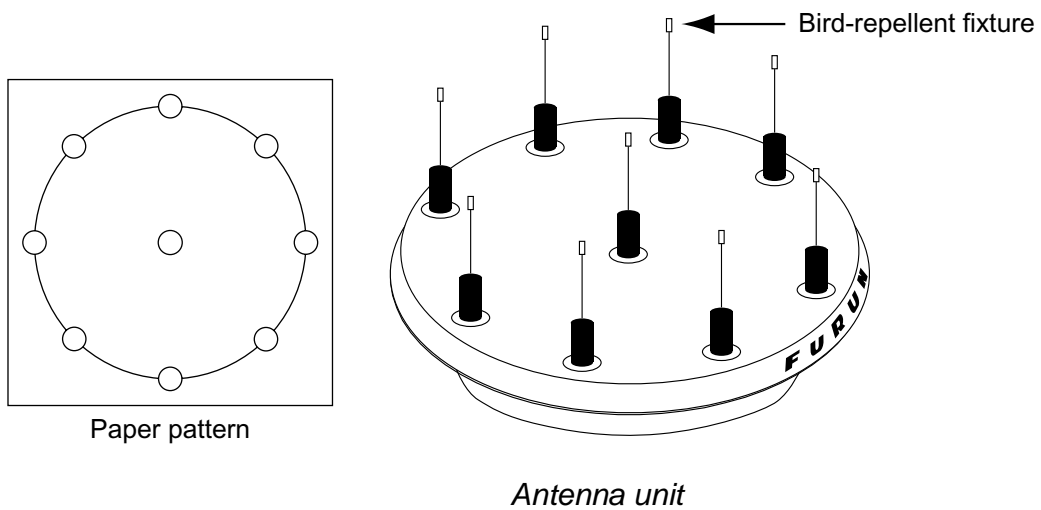

2.2.2 Antenna unit SC-603

Note: “Bird-repellent fixtures” may be attached to each antenna element and the Antenna Cover S to prevent birds from alighting on them. If it is more convenient to attach them before fixing the antenna unit to the mounting location, do step 10 in “Welding the antenna unit” before fixing the antenna unit.

Mounting

1. Screw in three antenna elements in the Antenna Base S. Remove Antenna Cover S and Arm Cover S.

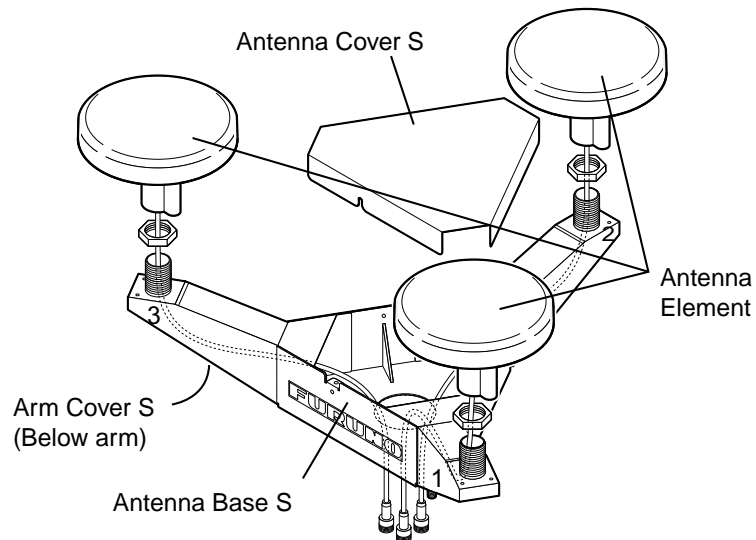

Antenna unit SC-603

2. Pass the coaxial cable from each antenna element through the center of the respective arm and then through the hole at the center of the antenna unit.
3. Orient the three antenna elements so that the protrusion on each faces the bow.

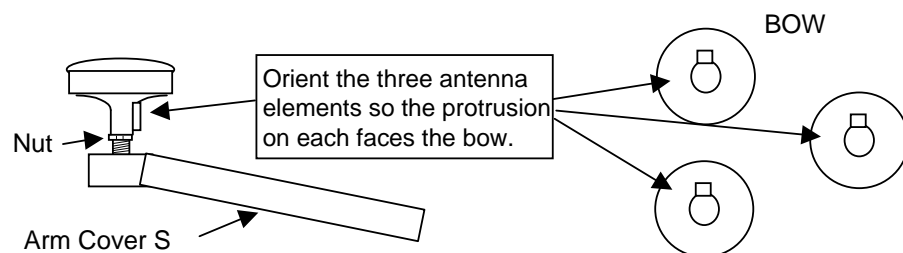

How to orient the antenna elements

2 INSTALLATION

1. Making sure each antenna element is correctly oriented, fix each with its nut. Write the corresponding arm number on each coaxial cable, using a magic marker. (When connecting with the coaxial cables from the processor unit it is necessary to match correct antenna element number with coaxial cable color.)

Arm [1]	1
Arm [2]	2
Arm [3]	3

2. Temporarily fix the pedestal and support plate to the antenna mast as shown in the illustration below. (The pedestal and support plate will be welded to the antenna mast after confirming that the installation site is suitable, following paragraph 2.6.)

Note: If U-bolts are used to temporarily fix the pedestal and support plate, DO NOT overtighten them – overtightening may deform the pedestal.

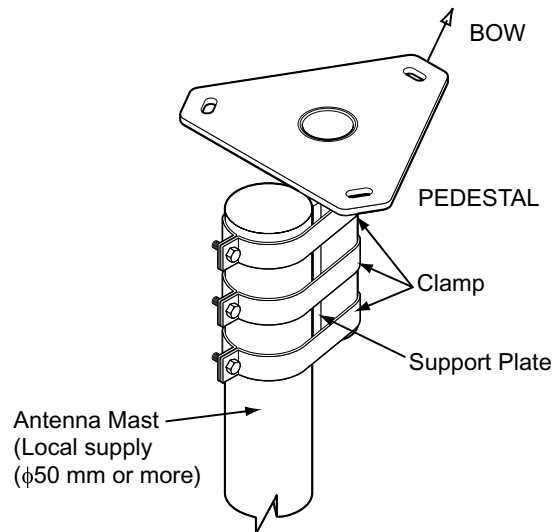

How to temporarily fix the support plate and pedestal to the antenna mast

3. Set the antenna unit to the pedestal.

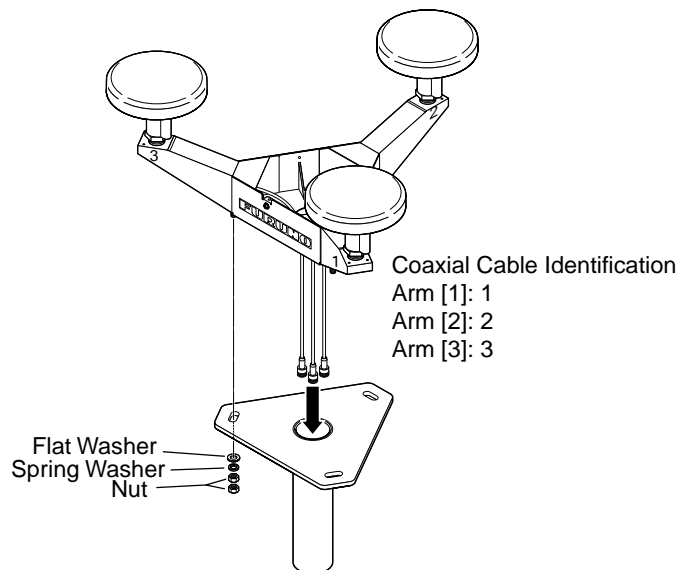

Fixing antenna unit to pedestal

4. Orient the antenna unit as shown in the illustration below.

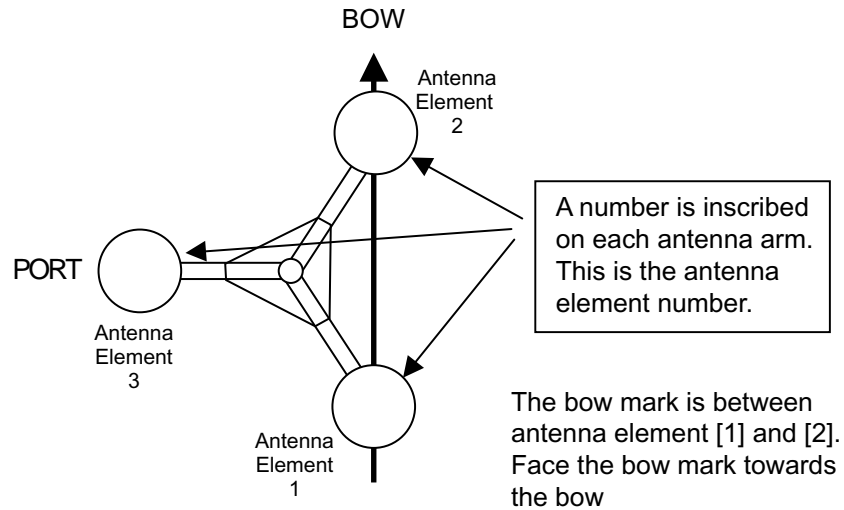

Orienting the antenna unit

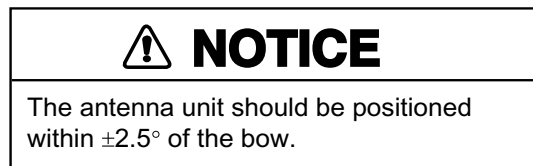

5. Fasten the Antenna Cover S with three screws.

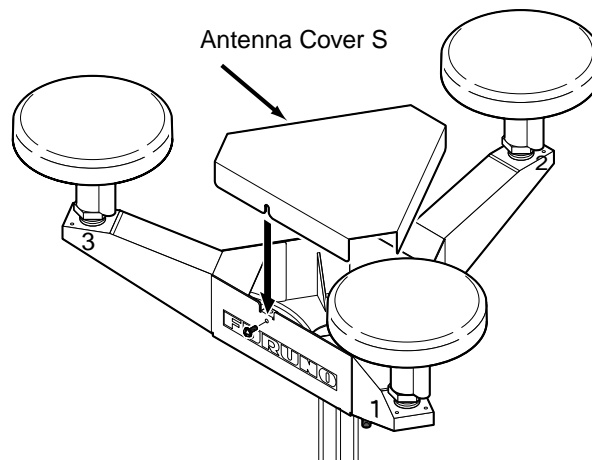

Antenna unit SC-603

6. Follow the instructions in the paragraph 2.6. If the satellite tracking status display shows "OK," the installation site is suitable. Weld the antenna unit to the antenna mast as shown in the next paragraph.

2. INSTALLATION

Welding the antenna unit

The antenna unit may be welded to the antenna mast if the satellite status display shows "OK."

1. Unfasten the coaxial cables and dismount the antenna unit.
2. Weld the pedestal and support plate to the antenna mast. Remove the clamps used to temporarily fasten the pedestal and support plate.
3. Fasten the coaxial cables and fix the antenna unit.
4. Wrap the antenna connector with self-vulcanizing tape and then vinyl tape for waterproofing as shown in the illustration below. Tie tape ends with cable ties to prevent unraveling.

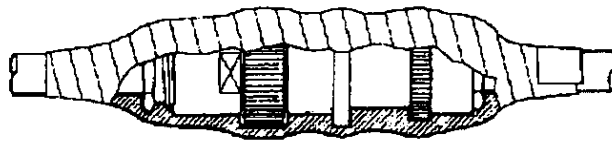

Waterproofing the antenna connector

5. Coat the three screws fixing the Antenna Cover S with Three Bond 1211 (supplied).

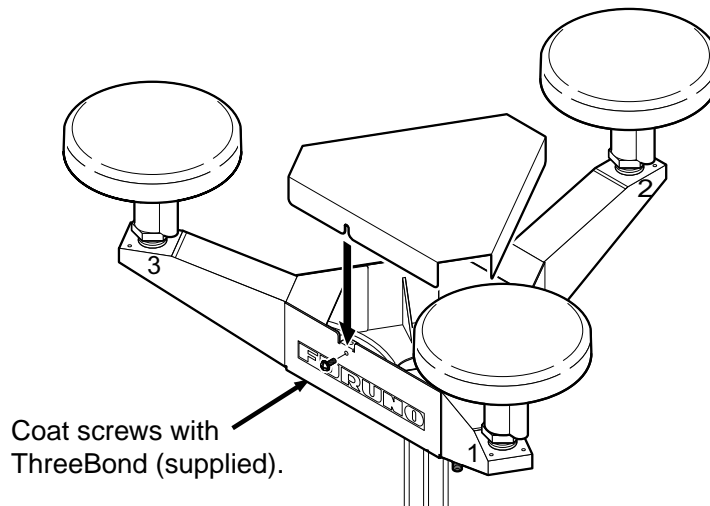

Antenna unit SC-603

6. Look at the heading indication on the display. If the heading error is between 5° and 10°, loosen the nut at the center of the antenna unit and adjust antenna orientation, while watching the heading indication on the display.

7. Make a loop in the antenna cable as shown in the illustration below. Fasten the antenna cable to the antenna mast with cable ties.

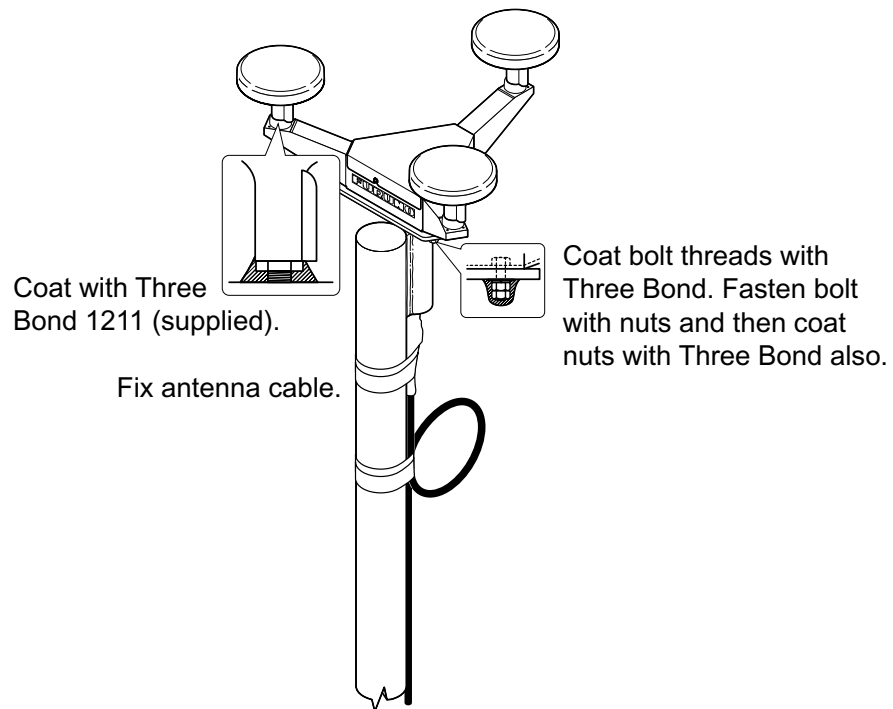

Fastening the antenna cable

8. Coat bolt threads and nuts at the bottom of each antenna element with Three Bond 1211.
9. Paint pedestal and support plate with anti-corrosive paint.
10. Attach the “bird-repellent fixtures” (supplied) to each antenna element and the Antenna Cover S as shown below.

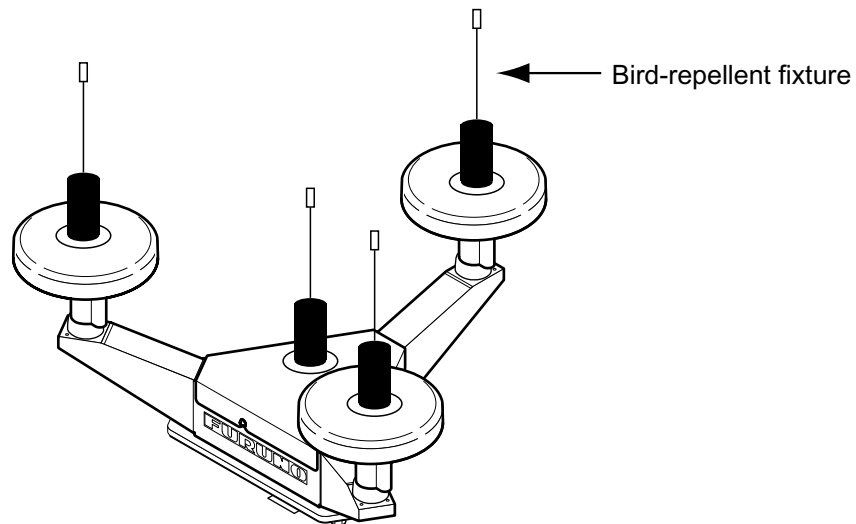

Antenna element

2.3 Installing the Processor Unit

The processor unit should be mounted aligned with the ship's fore-and-aft line. It can be mounted on the deck, bulkhead, or on the underside of a desk. Choose a mounting location which allows you to easily view the power lamp on the top of the unit and which is within $\pm 2.5^\circ$ of the ship's fore-and-aft line.

2.3.1 Deck, bulkhead mount

1. The processor unit is factory adjusted for deck mounting. Fasten the processor unit to the mounting location with tapping screws (5 x 20, 4 pcs.). The unit can also be oriented in one of the directions shown in the figure below. After the unit is installed, you will specify the mounting method from the menu.

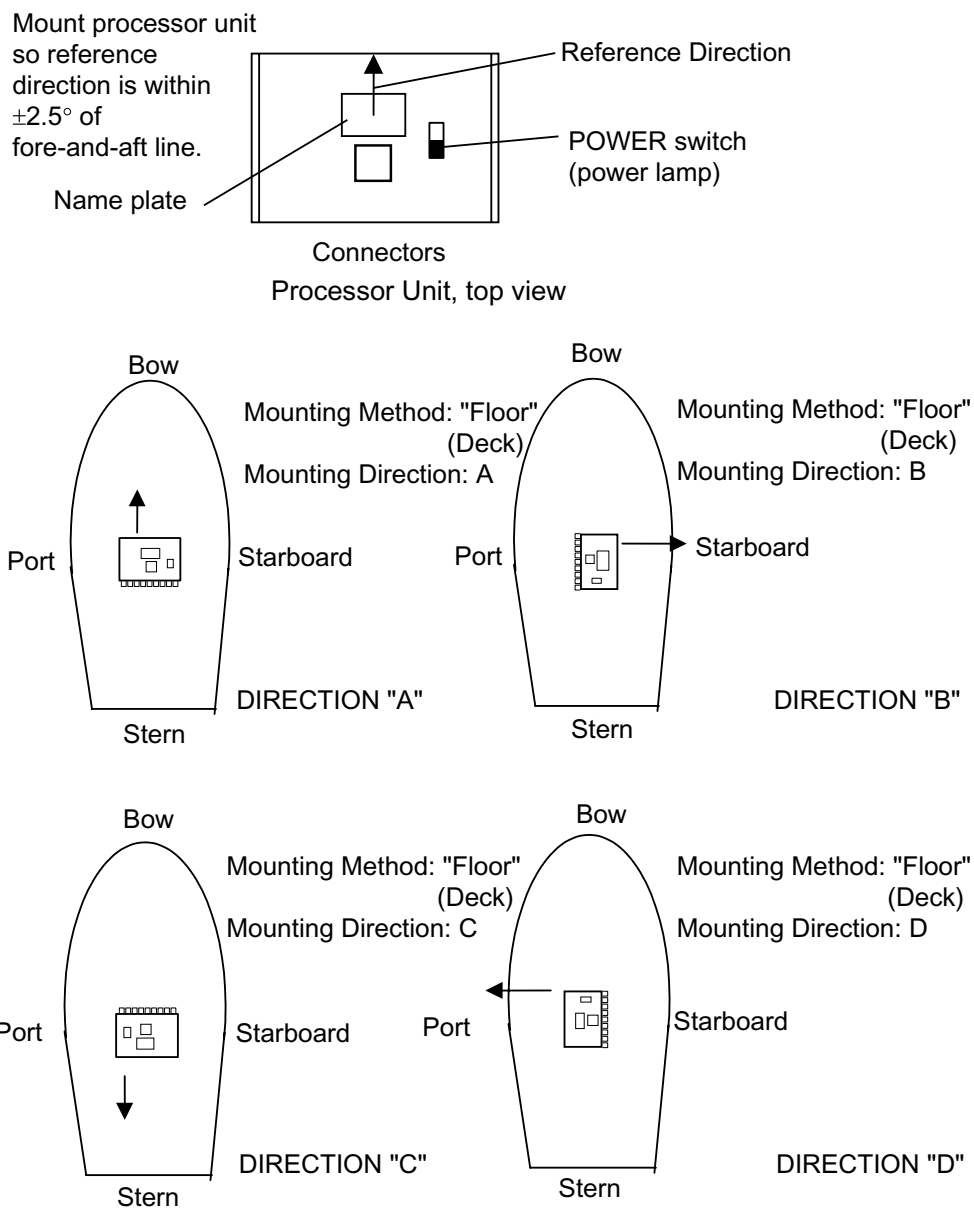

Processor unit orientation, deck mounting

2. Fasten the ground wire between the ground terminal on the processor unit and the ship's hull.

2.3.2 Installation on the underside of a desk

The processor unit may be mounted on the underside of a desk as shown in the figure below. **Do not install it on the overhead.**

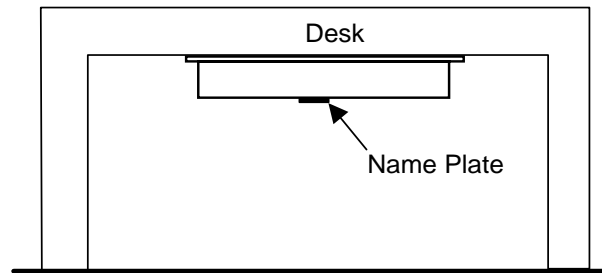

Installation of processor unit on the underside of a desk

2.4 Installing the Display Unit

2.4.1 Desktop, overhead mounting

1. Fasten the hanger to the mounting location with four tapping screws (supplied). See the outline drawing for mounting dimensions.
2. Screw the knobs into the display unit.
3. Set display unit to the hanger and tighten the knobs.
4. Run the ground wire between the ground terminal on the display unit and the ship's superstructure.

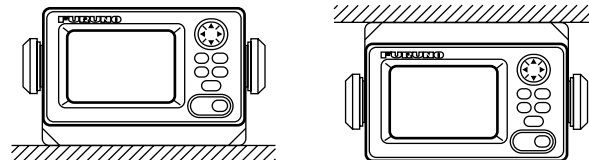

Desktop

Overhead

Display unit mounting methods

2.4.2 Flush mount

Two types of flush mounts are available. See the outline drawing at the back of the manual for details.

Flush mount “F”

Flush mount “F” kit Type: OP20-29, Code No: 000-041-405)

Name	Type	Code No.	Qty
Cosmetic Panel	20-016-1051	100-251-370	1
Tapping Screw	5X20	000-802-840	4
Hex Bolt	M6X12	000-862-127	2
Spring Washer	M6	000-864-260	2

1. Make a cutout in the mounting location. The dimensions are 183(W) x 92(H) mm.
2. Fasten the cosmetic panel to the display unit with hex bolts and spring washers.
3. Fasten the display unit to the mounting location with tapping screws.

Flush mount “S”*Flush mount “S” kit (Type: OP20-17, Code No.: 000-040-720)*

Name	Type	Code No.	Qty
Flush Mount Fixture	20-007-2401	100-183-190	2
Wing Bolt	M4X30	000-804-799	4
Wing Nut	M4	000-863-306	4
Hex Bolt	M6X12	000-862-127	2
Spring Washer	M6	000-864-260	2

1. Make a cutout in the mounting location. The dimensions are 167(W) x 92(H) mm.
2. Place the display unit in the cutout.
3. Fix the display unit to the two flush mount fixtures with hex bolts and spring washers.
4. Screw the butterfly nut on the butterfly bolt.
5. Fix the display unit with the butterfly bolt and then tighten the butterfly nut.

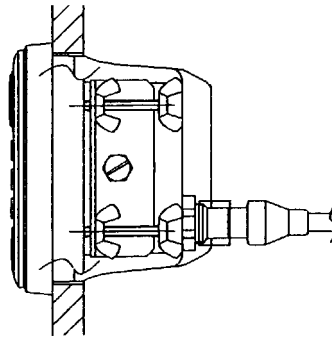
*Flush mount “S”*

2.5 Wiring

This section covers general wiring. For further details see the interconnection diagram at the back of this manual.

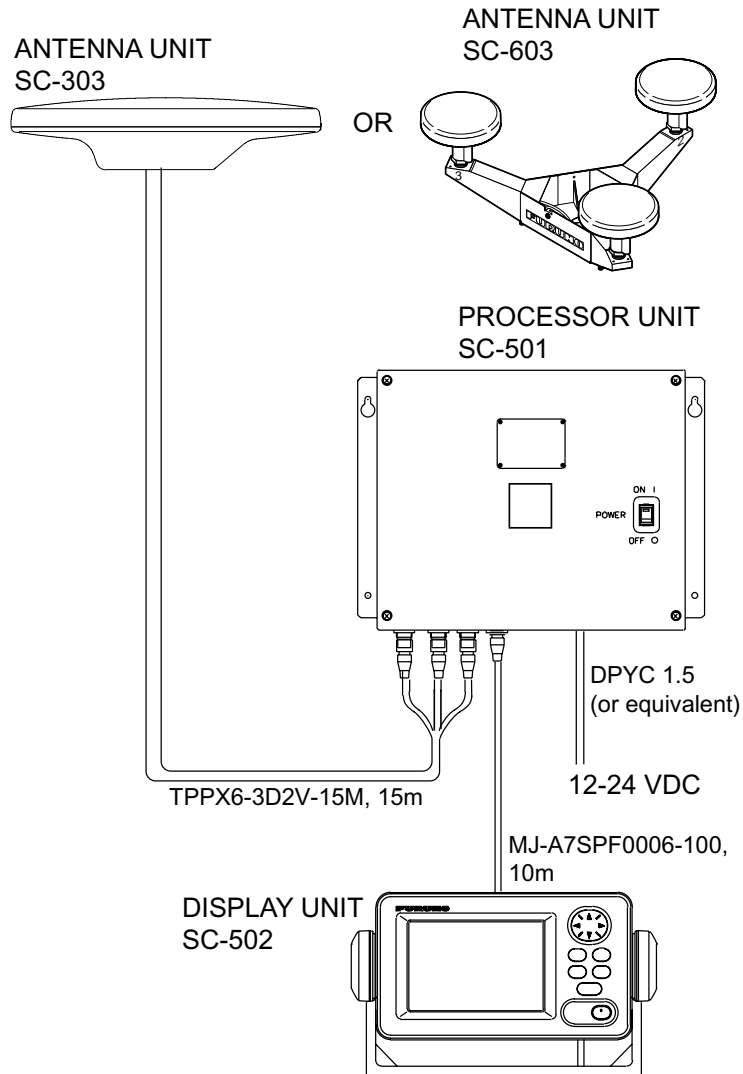

General wiring diagram

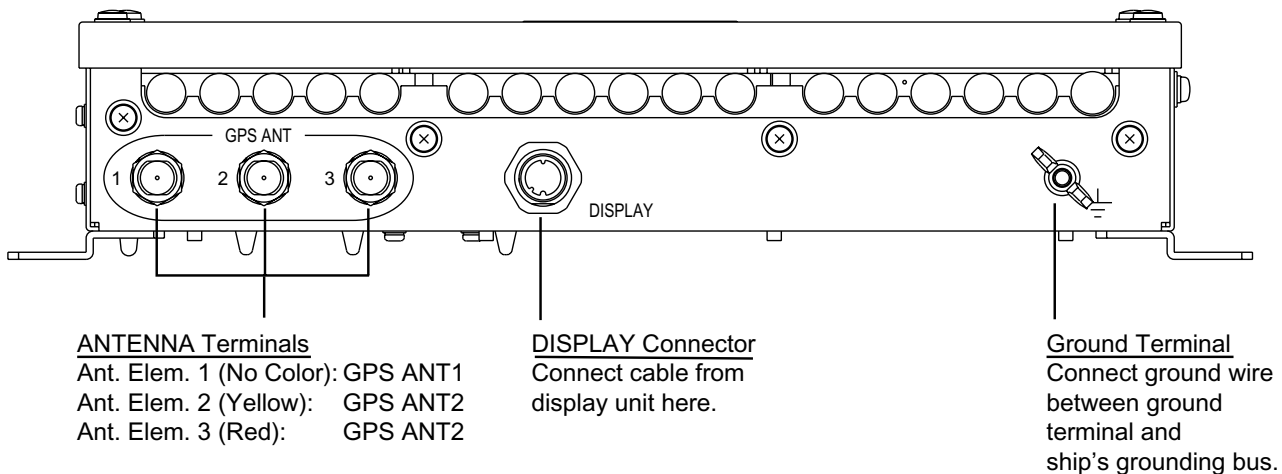

ANTENNA Terminals
 Ant. Elem. 1 (No Color): GPS ANT1
 Ant. Elem. 2 (Yellow): GPS ANT2
 Ant. Elem. 3 (Red): GPS ANT2

DISPLAY Connector
 Connect cable from display unit here.

Ground Terminal
 Connect ground wire between ground terminal and ship's grounding bus.

Processor unit, rear view

Note 1: Instead of cable TPPX6-3D2V, three Japan Industrial Standard coaxial cables 3D2V (local supply) or equivalent can be used as antenna cables.

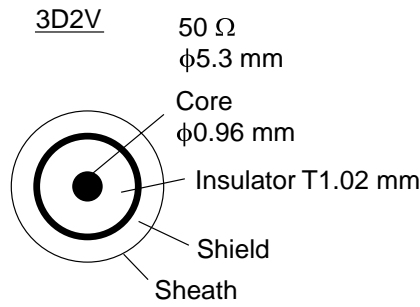

Sectional view of coaxial cable 3D2V

Note 2: The optional antenna cable set (CP20-01700 or CP20-01710) allows you to extend antenna cable length to 30 m (50 m). See next page for how to attach the connector.

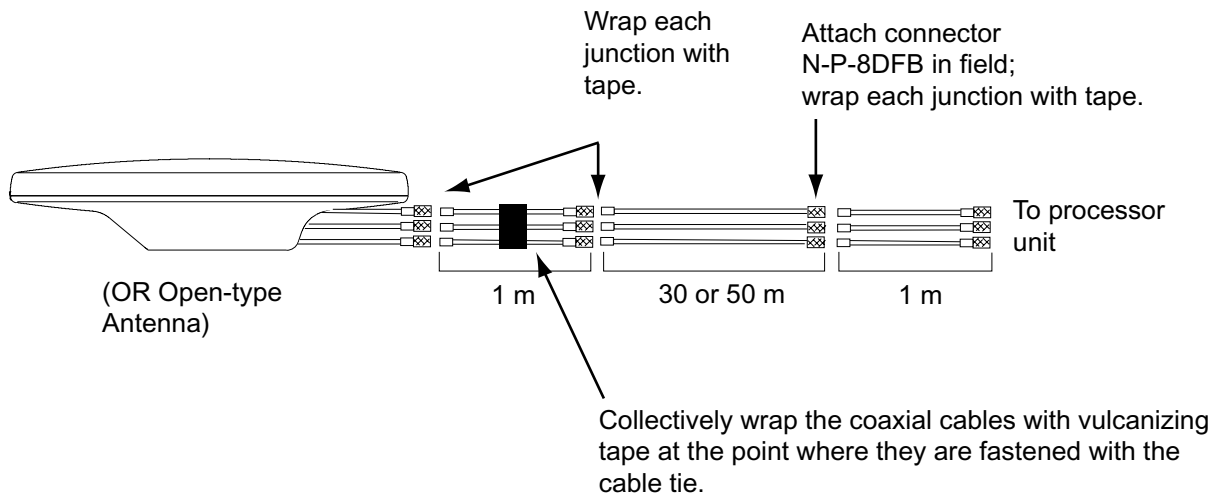

How to install the optional antenna cable set

How to attach connector N-P-8DFB

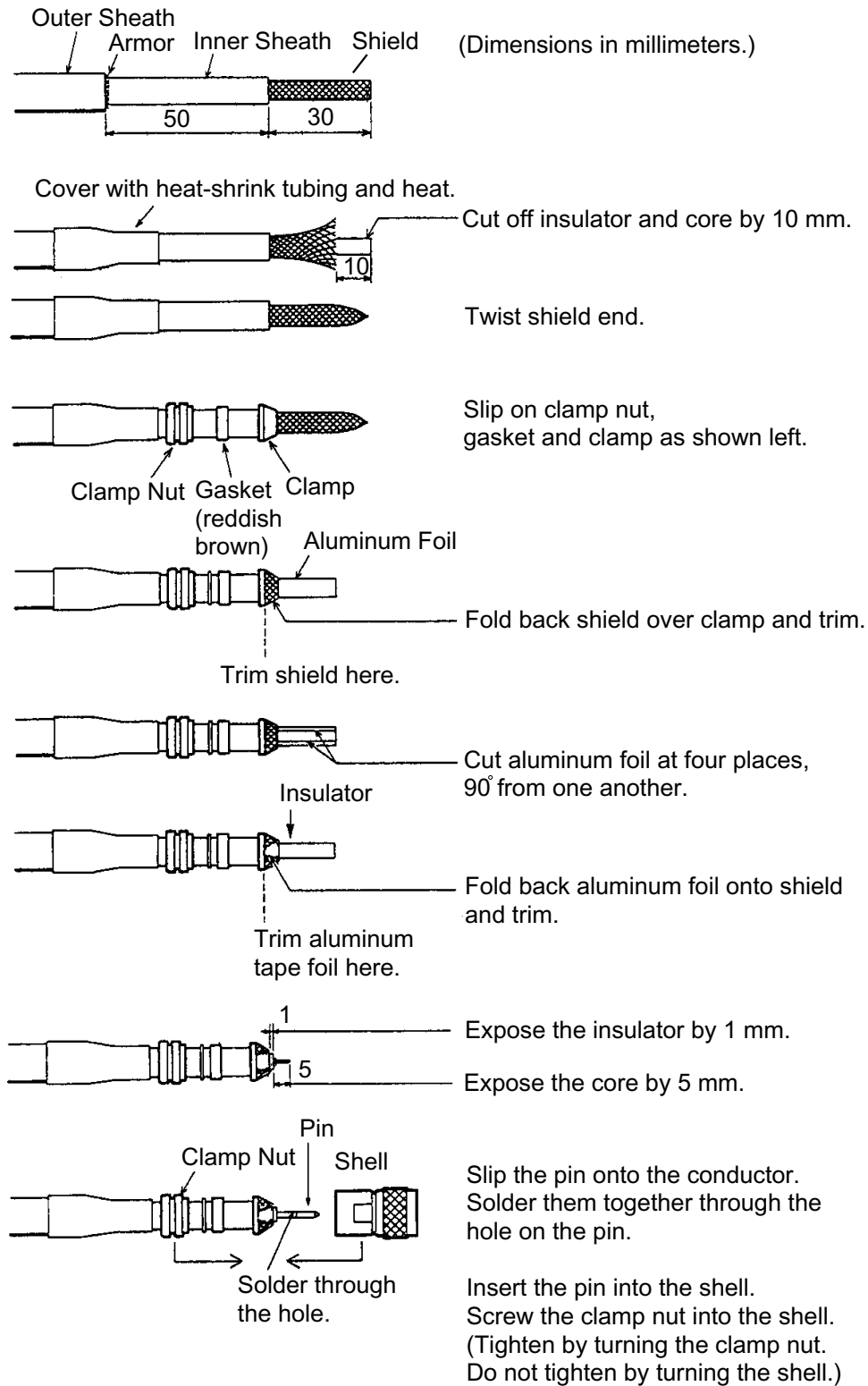

How to attach connector N-P-8DFB

2.6 Initial Settings

Follow the procedures in this section to enter initial settings.

 NOTICE
Improper menu settings may stop output of data and display the message "RATE ERROR." Be sure to enter correct data.

2.6.1 Confirming satellite status; choosing mounting method

1. Turn on the processor unit and then press the [MENU] key to show the menu.

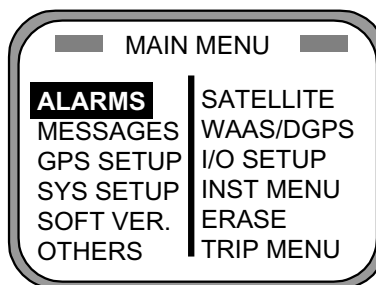

Main menu

2. Use the Omnipad (☺) to choose "INST MENU" and then press the [ENT] key.

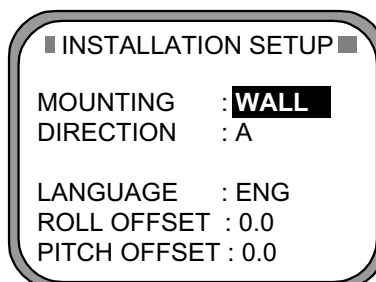

Installation setup menu

3. Confirm that "MOUNTING" is selected and then press the [ENT] key.
4. Use the Omnipad to choose the mounting method: "FLOOR", "WALL" or "INVERT" as appropriate.
5. Press the [ENT] key.
6. Choose "DIRECTION" and then press the [ENT] key.
7. Use the Omnipad to choose mounting direction ("A", "B", "C" or "D") as appropriate. Refer to section 2.3.1.
8. Press the [ENT] key.
9. Press the [SAT STATUS] key.

2. INSTALLATION

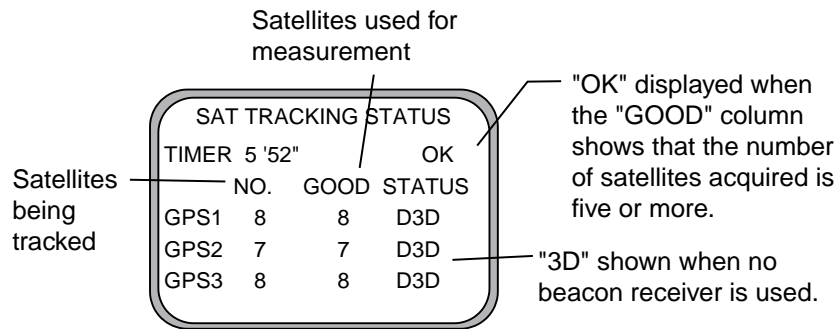

Satellite tracking status display

When the system is turned on for the first time it is in the "cold-start" state, which means there is no satellite data (almanac data) stored. In this condition it takes about 20 minutes to find heading. When heading is found the display shows "OK." The timer at the top left corner of the screen shows time since power on. If OK is not displayed within 30 minutes after turning on the power, the antenna mounting location may not be suitable. Suspect that the number of satellites in view is less than five due to signal blockage. Resolve the problem and then recheck tracking status.

If the heading error is between 5° and 10°, adjust orientation of the antenna unit, while watching the heading indication on the display. (For the open-type antenna, loosen the nut at the center of the antenna unit to adjust antenna orientation.)

2.6.2 Choosing heading source

Choose the source of heading data as below.

⚠ CAUTION

Never switch from internal to external heading while the autopilot is in the automatic mode. Change to the manual mode before switching.

1. Press the [HDG SETUP] key.

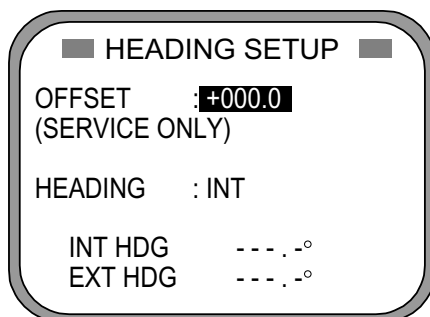

- OFFSET : Heading offset. See service manual for instructions. "SERVICE ONLY" means heading offset shown for display only.
- HEADING : Select heading source. Choose INT for normal use. If a gyrocompass is connected for primary means, leaving this equipment as backup, choose EXT.
- INT HDG : Bow heading. Includes offset.
- EXT HDG : Heading fed from external equipment.

Heading setup menu

2. Use the Omnipad to choose HEADING.
3. Press the [ENT] key.

4. Choose INT or EXT as appropriate. Normally choose INT. If own GPS sensor is not working and a heading sensor such as a gyrocompass is available, choose EXT.
5. Press the [ENT] key.
6. Press the [DISP] key to close the menu.

2.7 Connection of External Equipment

2.7.1 General wiring

All external equipment are terminated on the MAIN Board inside the processor unit. Turn off the power and unfasten four screws to remove the cover. Connect wiring from external equipment referring to the interconnection diagram. Use the lever supplied to open terminal blocks, referring to the instructions below.

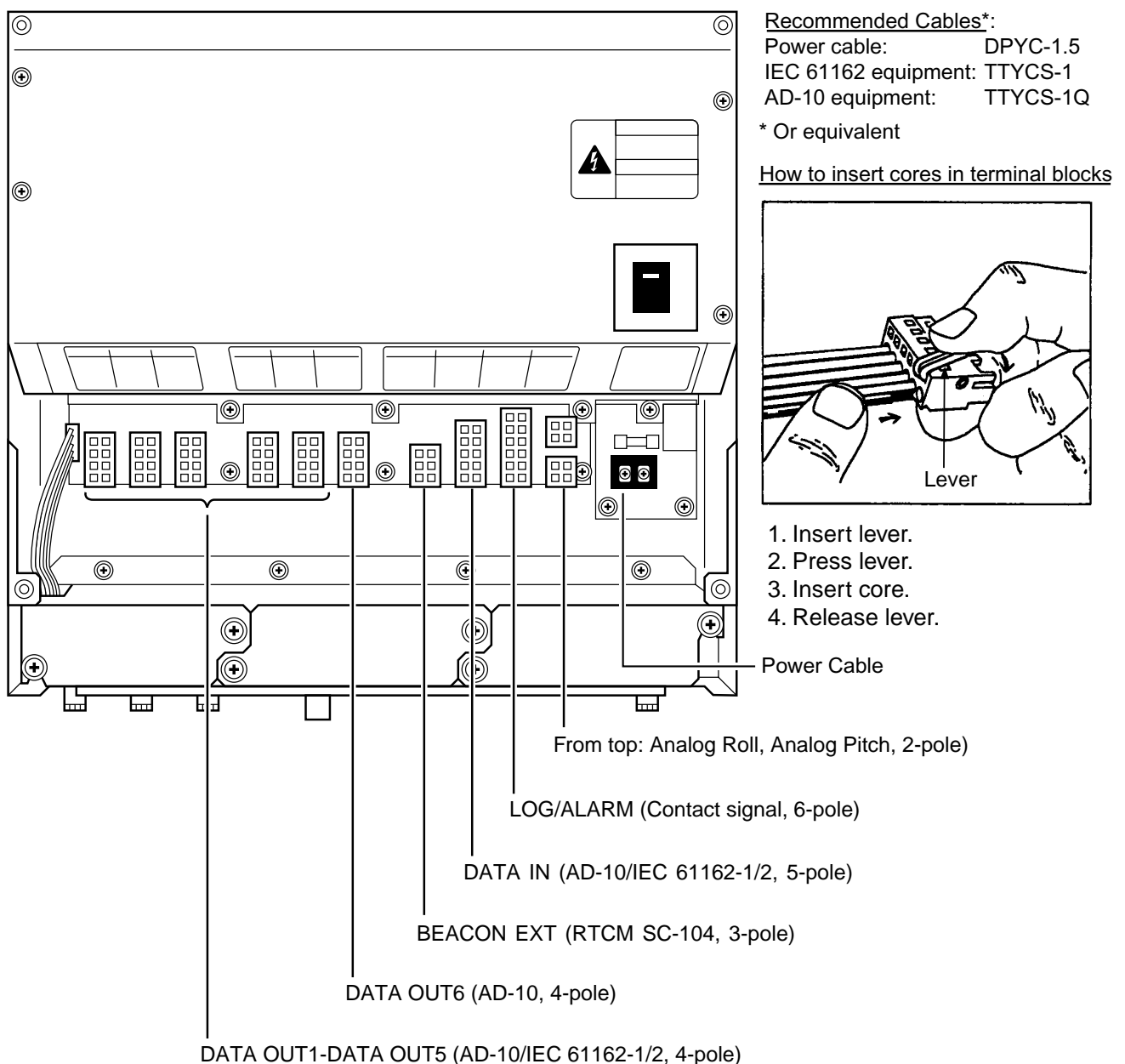

Processor unit, cover opened

2.7.2 Fabrication of cables

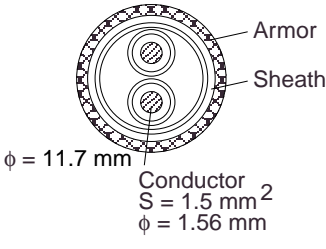
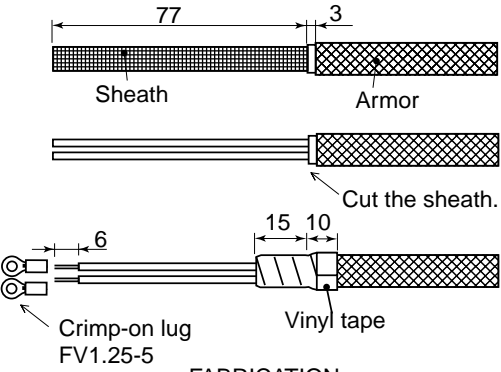
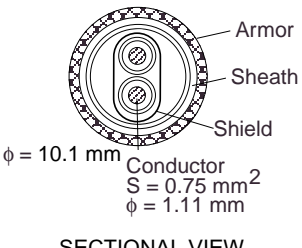
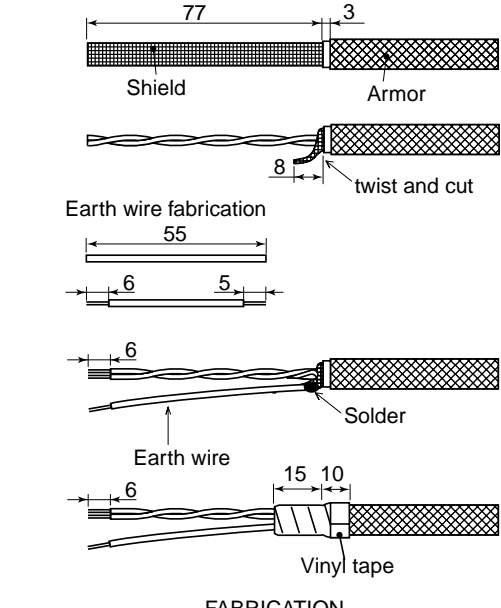
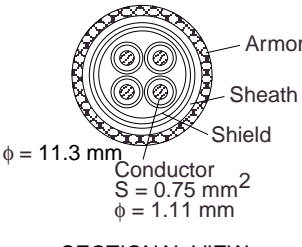
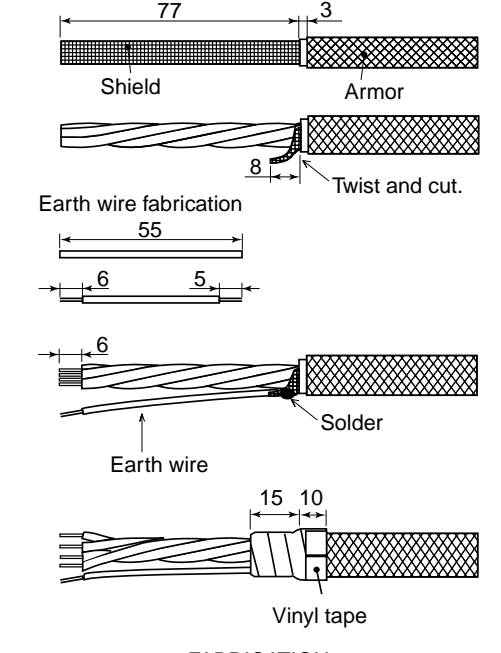
Cable	Sectional view, fabrication
<p>Power cable DPCY-1.5 (or equivalent)</p>  <p>$\phi = 11.7 \text{ mm}$ Conductor $S = 1.5 \text{ mm}^2$ $\phi = 1.56 \text{ mm}$</p> <p><u>SECTIONAL VIEW</u></p>	 <p>77 3 Sheath Armor Cut the sheath. 6 15 10 Crimp-on lug Vinyl tape FV1.25-5</p> <p><u>FABRICATION</u></p>
<p>Cable for IEC 61162 format equipment (JIS cable TTYCS-1 or equivalent)</p>  <p>$\phi = 10.1 \text{ mm}$ Conductor $S = 0.75 \text{ mm}^2$ $\phi = 1.11 \text{ mm}$</p> <p><u>SECTIONAL VIEW</u></p>	 <p>77 3 Shield Armor twist and cut 8 Earth wire fabrication 55 6 5 6 Solder Earth wire 6 15 10 Vinyl tape</p> <p><u>FABRICATION</u></p>
<p>Cable for AD-10 format equipment (JIS cable TTYCS-1Q or equivalent)</p>  <p>$\phi = 11.3 \text{ mm}$ Conductor $S = 0.75 \text{ mm}^2$ $\phi = 1.11 \text{ mm}$</p> <p><u>SECTIONAL VIEW</u></p>	 <p>77 3 Shield Armor Twist and cut. 8 Earth wire fabrication 55 6 5 6 Solder Earth wire 6 15 10 Vinyl tape</p> <p><u>FABRICATION</u></p>

3 OPERATION

3.1 Controls

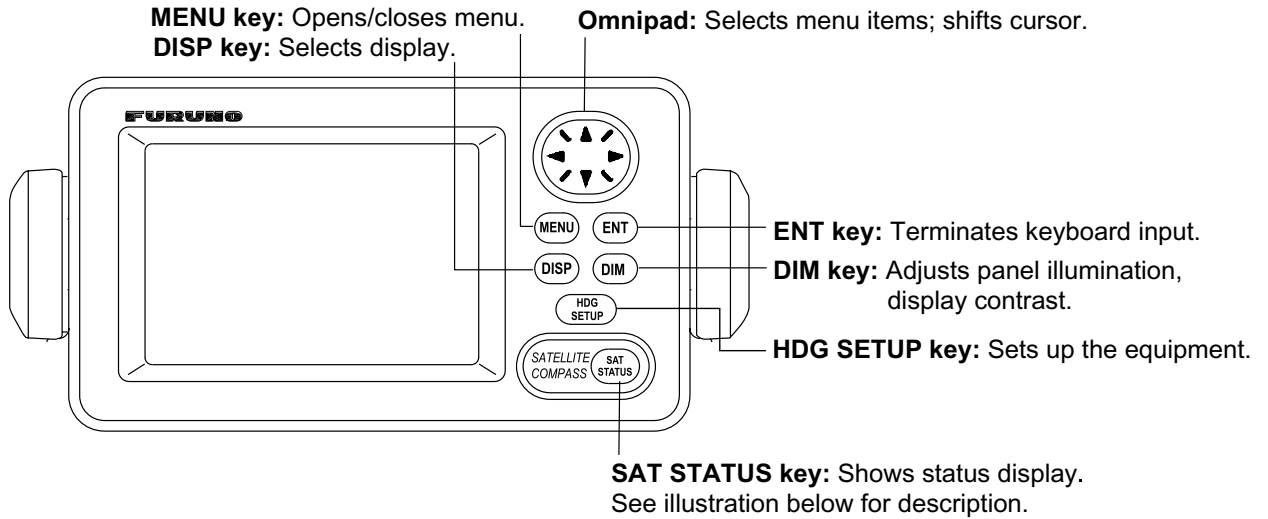

HOW TO REMOVE THE COVER

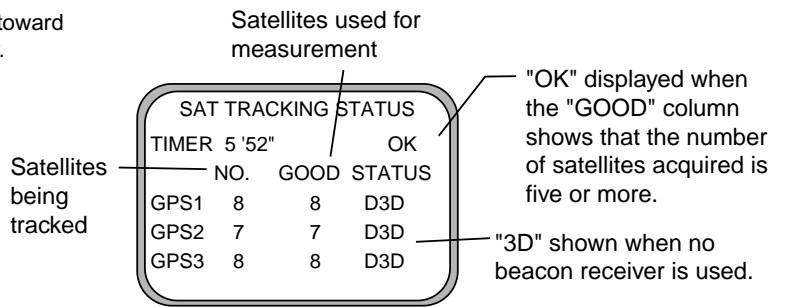
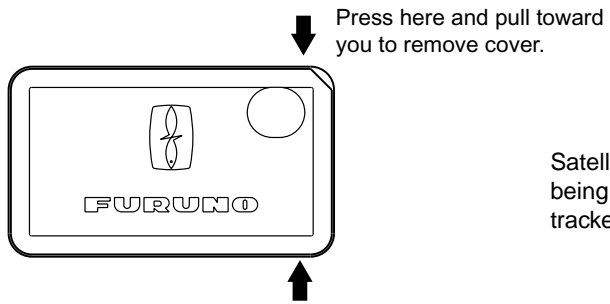

Display unit

CAUTION

Reduced accuracy may occur in case of unfavorable satellite constellation, worsened HDOP, etc.

Always confirm position against other navigation devices to verify reliability.

3.2 Turning the Power On/Off

Use the power switch on the processor unit to turn the power to the display unit on and off.

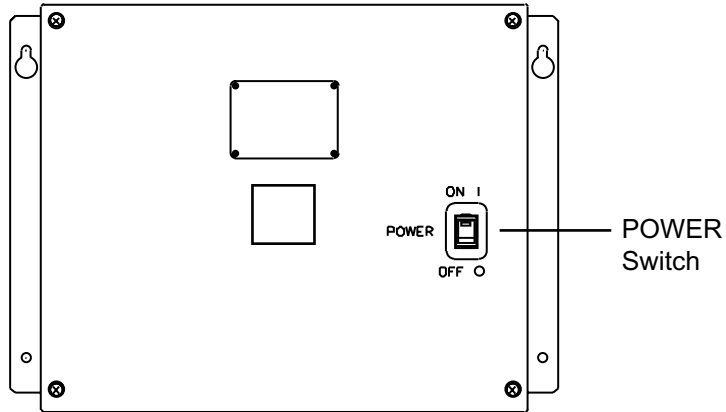

Processor unit

The display starts up with the last-used display.

Note 1: Turn on external equipment **AFTER** the SC-50 is showing reliable heading data, to prevent heading output error.

Note 2: The display flashes when backup heading data is being used.

3.3 Panel Illumination, Display Contrast

1. Press the [DIM] key.

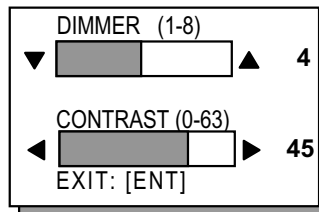

Dialog box for adjustment of panel illumination, display contrast

2. Press ▲ or ▼ to adjust panel illumination.
3. Press ◀ or ▶ to adjust display contrast.
4. Press the [ENT] key.

3.4 Choosing a Display

Use the [DISP] key to show a display desired.

3.4.1 Description of displays

Heading display

The heading display shows heading, course, speed, date, time and position-fixing method. The heading status mark changes in the sequence shown below. The “final calculations” mark disappears after heading becomes reliable, which is approximately 90 seconds after that mark appears.

Position-fixing status indications

2D	2D GPS position fix
3D	3D GPS position fix
D2D	2D DGPS position fix
D3D	3D DGPS position fix
SIM	Simulation mode
W2D	WAAS 2D position fix
W3D	WAAS 3D position fix

Heading Status Mark

- = Acquiring satellite
- = Calculating heading
- ☉ = Final calculations

When the data of external sensor is input, EXT (in reverse video) replaces HDG on the Heading, Nav data, Steering and Compass displays.

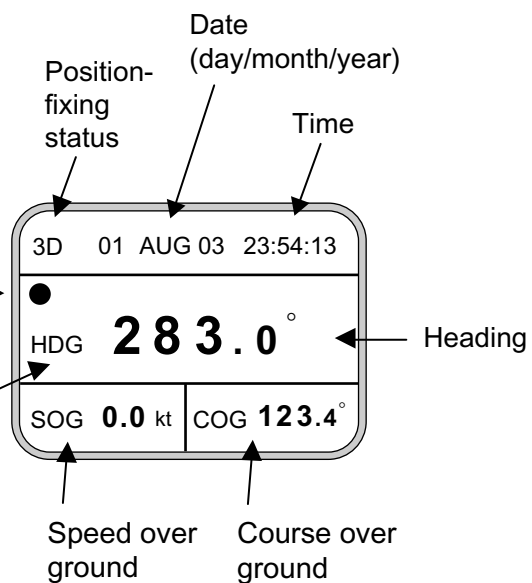

Nav data display

The nav data display shows position in latitude and longitude, course, speed, date, time and position-fixing method.

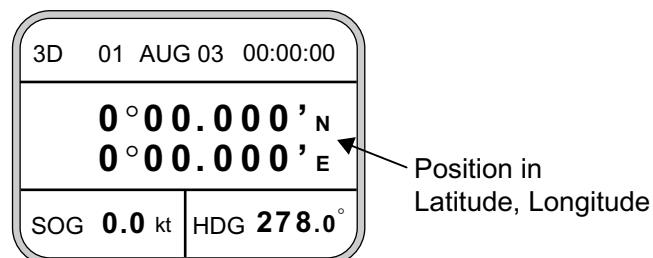

Nav data display

Steering display

The steering display shows heading in digital and analog form. SOG and COG are also indicated. Note that COG accuracy is low when the own ship speed is low. The faster the speed, the more accurate the COG.

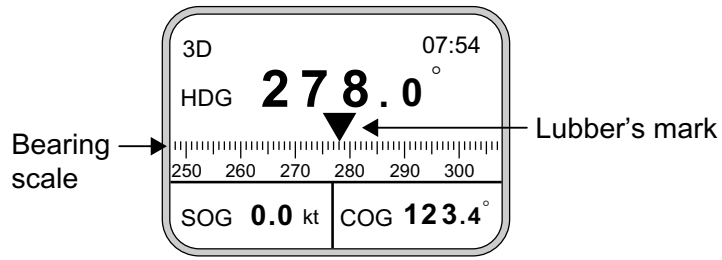

Steering display

Compass display

The compass display shows heading by compass direction. Pitch and roll are also indicated. The compass rose rotates with heading.

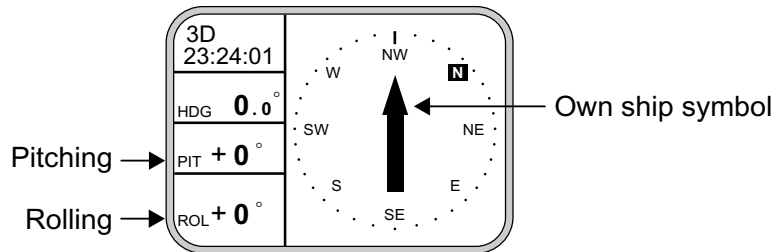

Compass display

ROT (Rate-of-Turn) display

The ROT display provides digital and analog indications of rate of turn.

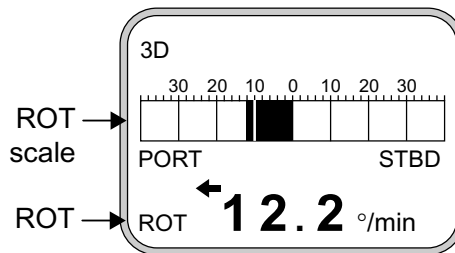

ROT display

Set and Drift display, Distance Run display

Depending on the setting of DISTANCE DISP on the TRIP menu, the Set and Drift display or the Distance Run display is shown. The Set and Drift display requires the Doppler Speed Log DS-80 and it shows current direction and speed.

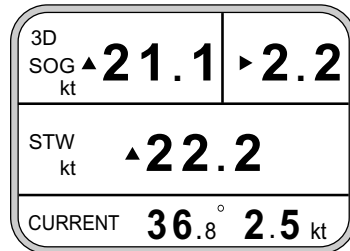

Set and Drift display

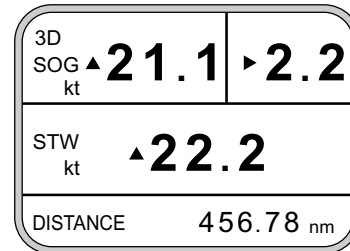

Distance Run display

Set and drift display, speed and distance run display

3.5 DGPS Alarm Setup

The SC-50 can alert you with audible and visual alarms when GPS data, DPGS data and WAAS data are lost. To set the DGPS alarm, do the following:

1. Press the [MENU] key to show the menu.

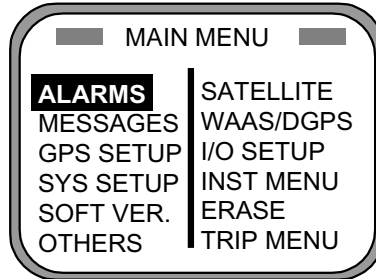

Main menu

2. Choose ALARMS and then press the [ENT] key.

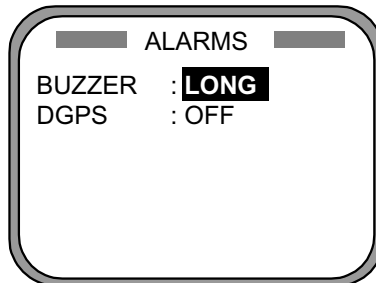

Alarm menu

3. BUZZER is selected; press the [ENT] key.

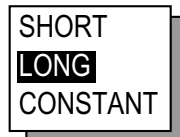

Buzzer options

4. Use ▲ or ▼ to choose buzzer type desired and then press the [ENT] key.

SHORT: Two short beeps
 LONG: Three long beeps
 CONSTANT: Continuous beep

5. Press the [ENT] key.
6. Use ▼ to choose DGPS and then press the [ENT] key.



DGPS alarm options

7. Use ▲ or ▼ to choose OFF or ON as appropriate.
8. Press the [ENT] key.
9. Press the [DISP] key to close the menu.

3.6 Confirming Satellite Status

You can check the receiving condition of each antenna unit as follows:

1. Press the [MENU] key to open the menu.
2. Choose SATELLITE and then press the [ENT] key.

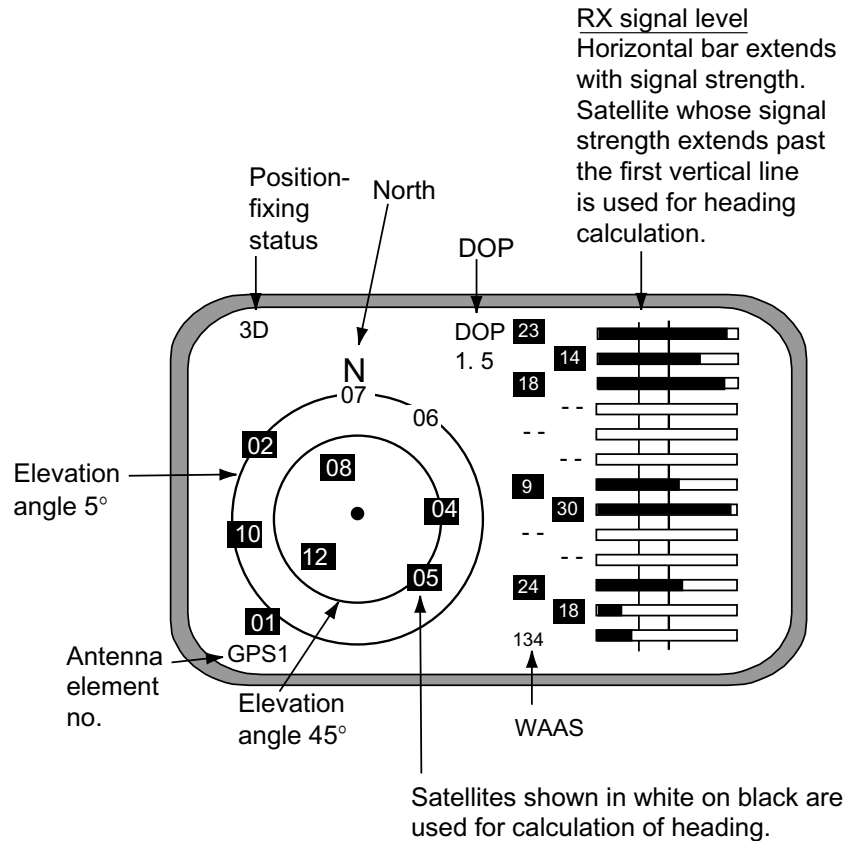

Satellite status display

3. Use ◀ or ▶ to choose antenna element for which to confirm receiving status.
4. Press the [DISP] key to close the menu.

3.7 GPS Setup

The GPS SETUP menu smoothes position and course, averages speed, applies position offset, and deactivates unhealthy satellites.

3.7.1 Displaying the GPS setup menu

1. Press the [MENU] key to open the menu.
2. Choose GPS SETUP and then press the [ENT] key.

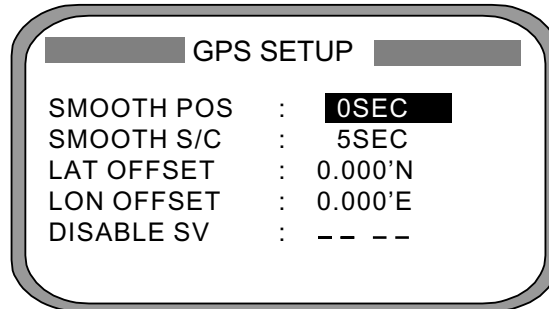

GPS SETUP menu

3.7.2 GPS SETUP menu description

SMOOTH POS (Smoothing position)

When the DOP (Dilution of Precision, the index for position-fixing accuracy) or receiving condition is unfavorable, the GPS fix may change randomly, even if the vessel is at anchor. This change can be smoothed by averaging a number of GPS fixes. The setting range is from 0 (no smoothing) to 999 seconds, and the default is 5 s, which is good for a rolling period of 5-8 s. The higher the setting, the more smoothing. However, too high a setting slows updating of position. "0" is the default setting; increase the setting if the GPS fix fluctuates largely.

SMOOTH S/C (Smoothing speed/course)

Ship's speed and course are directly measured by receiving GPS satellite signals, independent of positions. The data varies with receiving conditions and other factors. You can reduce this random variation by increasing the smoothing. The higher the setting, the more that speed and course are smoothed. If the setting is too high, however, the follow-up to actual values gets slower. The setting range is from 0 (no smoothing) to 999 seconds.

LAT/LON OFFSET (L/L position offset)

If GPS fixes are erroneous while at anchor, enter a position offset to compensate for position error. Consult a nautical chart to determine latitude and longitude differences between the chart and GPS display. Enter that value as the offset.

DISABLE SV (Disable satellite)

Every GPS satellite is broadcasting abnormal satellite number(s) in its Almanac, which contains general orbital data about all GPS satellites. Using this information, the GPS receiver automatically eliminates any malfunctioning satellite from the GPS satellite schedule. However, the Almanac sometimes may not contain this information. If you hear of an inoperative satellite you can disable it manually. Enter satellite number in two digits and then press the [ENT] key. To restore a satellite, enter "00".

3.8 Output Data**3.8.1 Heading**

Heading data is output from the HDG OUT port on the processor unit, in IEC 61162-1/2 format.

1. Press the [MENU] key to open the menu.
2. Choose I/O SETUP and then press the [ENT] key.

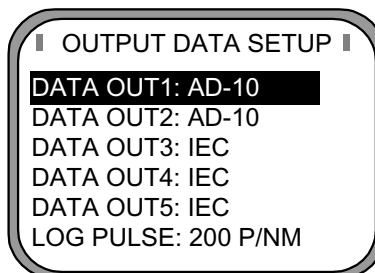

OUTPUT DATA SETUP menu

3. Choose DATA OUT1 and then press the [ENT] key.

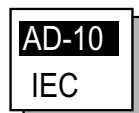

Data out options

4. Use the Omnipad to choose AD-10 or IEC as appropriate and then press the [ENT] key. If you choose AD-10, no further operation is required; go to step 19 to finish. For IEC go to the next step.

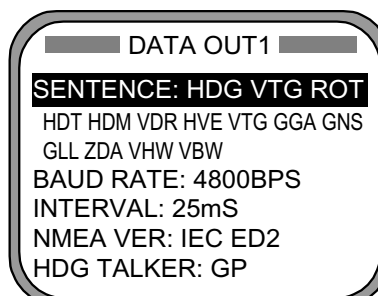

DATA OUT1 menu

3. OPERATION

5. Choose SENTENCE and then press the [ENT] key.

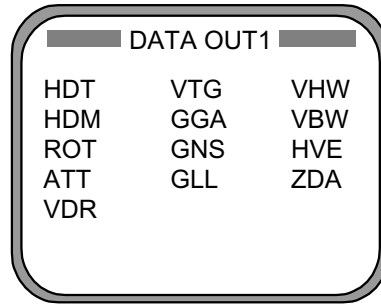

DATA OUT1 menu, sentences

6. Use the Omnipad to choose the sentence to process and then press the [ENT] key.
 - HDT: True heading (required for radar, AIS, ECDIS, etc.)
 - HDM: Magnetic heading (Some boaters may want magnetic heading when the boat is fitted with only a magnetic compass without correction of deviation and variation. HDM is obtained in this equipment by adding the magnetic variation to HDT automatically.)
 - ROT: Rate-of-turn data
 - ATT: True heading, pitching, rolling (FURUNO's proprietary sentence)
 - VDR: Set and drift
 - VTG: Course over ground and ground speed
 - GGA: Global positioning system (GPS) fix data
 - GNS: GNSS fix data
 - GLL: Geographic position, latitude/longitude
 - VHW: Water speed and heading
 - VBW: Dual ground/water speed
 - HVE: Pitch and roll data (FURUNO's proprietary sentence)
 - ZDA: Time and date



7. Use the Omnipad to choose OFF or ON as appropriate and then press the [ENT] key. Sentences selected for output are marked with an asterisk.
8. Choose item desired and then press the [ENT] key.
9. Choose ON or OFF as appropriate and then press the [ENT] key.
10. Press the [MENU] key to return to the DATA OUT1 menu.
11. Choose BAUD RATE and then press the [ENT] key.

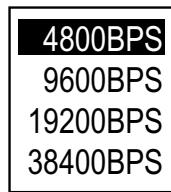

Baud rate options

12. Use the Omnipad to choose the baud rate of the equipment connected and then press the [ENT] key.
13. INTERVAL is selected; press the [ENT] key.

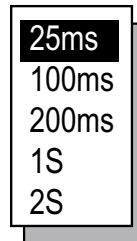

Tx interval options

14. Use the Omnipad to choose appropriate output interval and then press the [ENT] key.
15. Choose IEC VERSION and then press the [ENT] key.

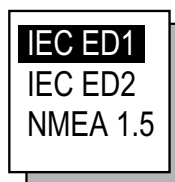

IEC, NMEA version options

16. Choose appropriate IEC (or NMEA) edition and then press the [ENT] key.
17. Choose HDG TALKER and then press the [ENT] key.

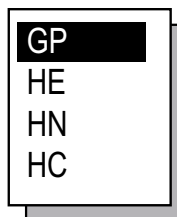

Heading talker options

18. Choose appropriate heading talker and then press the [ENT] key. If an external gyrocompass is used, choose HC.

GP: GPS navigator
 HE: North-seeking gyrocompass
 HN: Non-north seeking gyrocompass
 HC: Gyrocompass

19. Press the [DISP] key to close the menu, or press the [MENU] key several times to return to the I/O SETUP menu to setup another output port.

3.8.2 Log pulse

This equipment provides SOG (speed over ground) in high accuracy. It converts an SOG value to a closure signal and outputs at the rate of 200 or 400 pulses/nm.

1. Press the [MENU] key.
2. Choose I/O SETUP and then press the [ENT] key.
3. Choose LOG PULSE and then press the [ENT] key.

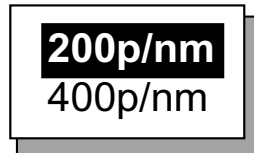

Log pulse options

4. Choose 200p/nm or 400p/nm as appropriate and then press the [ENT] key.
5. Press the [DISP] key to close the menu.

3.9 System Setup

3.9.1 Geodetic data

Your unit is preprogrammed to recognize most of the major chart systems of the world. Although the WGS-84 system (default setting) is the GPS standard, other categories of charts in other datum still exist. Match the GPS datum with the chart system you use.

1. Press the [MENU] key to open the menu.
2. Choose SYS SETUP and then press the [ENT] key.

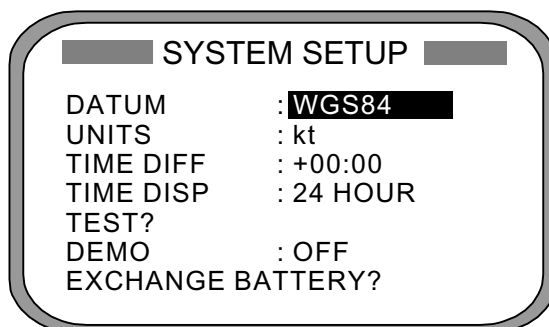

SYSTEM SETUP menu

3. Confirm that the cursor is selecting DATUM and then press the [ENT] key.
4. Choose WGS84 (GPS standard), WGS72 or OTHER according to the nautical chart you use and then press the [ENT] key.
5. If you chose WGS72 or WGS84, press the [DISP] key to finish. For OTHER, go to step 6.
6. Press the [ENT] key.
7. Use the Omnipad to enter chart number, referring to the geodetic chart list on page A-2. Choose location with ◀ or ▶; change value with ▲ or ▼.
8. Press the [ENT] key.
9. Press the [DISP] key to close the menu.

3.9.2 Units of measurement

Distance/speed can be displayed in nautical miles/knots, kilometers/kilometers per hour, or miles/miles per hour.

1. Press the [MENU] key to open the menu.
2. Choose SYS SETUP and then press the [ENT] key.
3. Choose UNITS.
4. Press the [ENT] key.
5. Choose unit of measurement combination desired; kt, km/h, mi/h.
6. Press the [ENT] key.
7. Press the [DISP] key to close the menu.

3.9.3 Using local time

GPS uses UTC time. If you would rather use local time, enter the time difference (range: -13:30 to +13:30) between local time and UTC.

1. Press the [MENU] key to open the menu.
2. Choose SYS SETUP and then press the [ENT] key.
3. Choose TIME DIFF and then press the [ENT] key.
4. Press ▲ or ▼ to display + or – as appropriate.
5. Enter time difference with the Omnipad. Choose digit with ◀ or ▶; change value with ▲ or ▼.
6. Press the [ENT] key.
7. Press the [DISP] key to close the menu.

3.9.4 Time format

Time can be displayed in 12 hour or 24 hour format.

1. Press the [MENU] key to open the menu.
2. Choose SYS SETUP and then press the [ENT] key.
3. Choose TIME DISP and then press the [ENT] key.
4. Choose 12HOUR or 24HOUR as appropriate and then press the [ENT] key.
5. Press the [DISP] key to close the menu.

3.9.5 Demonstration mode

The demonstration mode provides simulated operation of the equipment.

1. Press the [MENU] key to open the menu.
2. Choose SYS SETUP and then press the [ENT] key.
3. Choose DEMO and then press the [ENT] key.
4. Choose ON or OFF as appropriate and then press the [ENT] key.
5. Press the [DISP] key to close the menu.

The indication SIM appears at the top of the screen when the demonstration mode is active. When the demonstration mode is first made active, SIMULATION MODE appears when the power is turned on and it is erased when any key is pressed.

3.10 WAAS/DGPS Setup

1. Press the [MENU] key to open the menu.
2. Choose WAAS/DGPS and then press the [ENT] key.

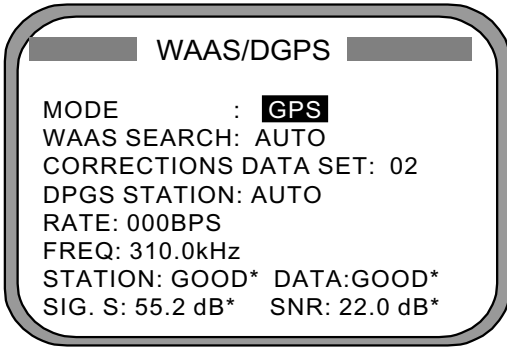

STATION: Shows GOOD or NG.
DATA: Shows GOOD or NG.
SIG. S: Signal Strength. A figure between 0 and 99 is shown. The higher the figure the stronger the beacon signal.
SNR: Signal to Noise Ratio. A figure between 1 and 22 is shown. When your boat is in the service area of a beacon station, SNR should be 21 or 22. If the figure is below 18 the position will be inaccurate. If this happens, check for radar interference, poor ground and generator noise on own ship.

WAAS/DGPS menu

3. MODE is selected; press the [ENT] key.

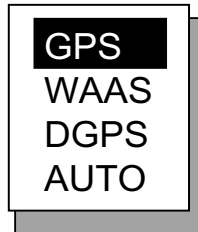

Position fix mode options

4. Choose appropriate mode referring to the description below and then press the [ENT] key.
 - GPS: Position fix by GPS
 - WAAS: Position fix by WAAS
 - DPGS: Position fix by DGPS (external beacon receiver required)
 - AUTO: Position fix in order of WAAS, DGPS and GPS
5. For WAAS or AUTO do as below. For GPS or DGPS go to step 6.
 - 1) WAAS SEARCH is selected; press the [ENT] key.

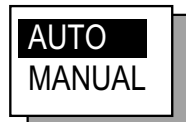

WAAS SEARCH options

- 2) Use the Omnipad to choose WAAS satellite search method, AUTO or MANUAL as appropriate. For MANUAL, press the [ENT] key, enter appropriate WAAS satellite referring to the illustration below and then press the [ENT] key.

Provider	GEO Satellite	Longitude
WAAS	POR (134)	178°E
	AOR-W (122)	54°W
EGNOS	AOR-E (120)	15.5°W
	IOR (131)	64.5°E

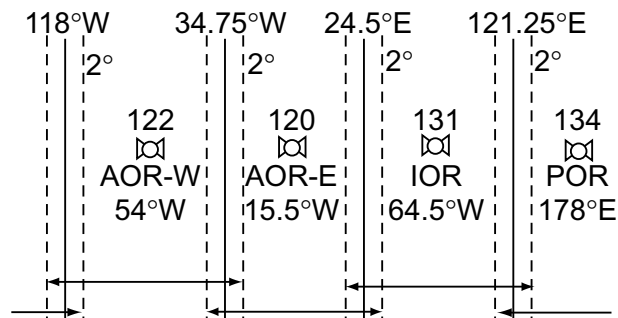

One-degree threshold

Longitude Range	Satellite
120.25°E to 117°W	134
119°W to 33.75°W	122
35.75°W to 25.5°E	120
23.5°E to 122.25°E	131

GEO satellite and coverage area

- 3) CORRECTIONS DATA SET is selected; press the [ENT] key.
 CORRECTIONS DATA SET determines how to use the WAAS signal, which is currently in the test mode. Use the default setting (02) until the WAAS system becomes operational, then change the setting to "00."
6. Choose DPGS STATION and press the [ENT] key.

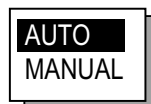

AUTO/MANUAL options

7. Choose MANUAL or AUTO as appropriate and press the [ENT] key. For AUTO got to step 8. For MANUAL do the following:
- 1) RATE is selected; press the [ENT] key.

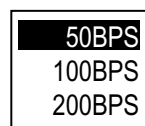

Baud rate options

3. OPERATION

- 2) Choose appropriate baud rate and press the [ENT] key.
 - 3) FREQ is selected; press the [ENT] key.
 - 4) The cursor is selecting the hundredths digit so press ▲ or ▼ to display appropriate digit. Press ► to shift the cursor to the tenths place.
 - 5) Set other digits appropriately.
8. Press the [DISP] key to close the menu.

3.11 OTHERS Menu

The OTHERS menu chooses whether to output last-used heading data, and smoothes rate of turn meter reading (rate-of-turn meter required).

1. Press the [MENU] key to display the main menu.
2. Choose OTHERS and then press the [ENT] key.

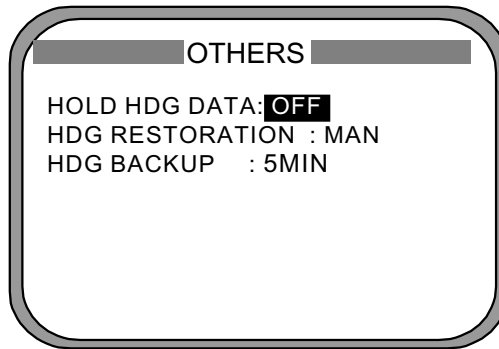

Others menu

3. Choose HOLD HDG DATA and then press the [ENT] key.
4. Choose ON to use, at power on, last-used heading until current heading is calculated. Last-used heading flashes to inform you that it is unreliable.
5. Press the [ENT] key.
6. Choose HDG RESTORATION and then press the [ENT] key.



HDG RESTORATION options

7. Use the Omnipad to choose how to restore GPS signal, automatically or manually, and then press the [ENT] key.
8. HDG BACKUP is selected; press the [ENT] key.



HDG BACKUP options

9. Enter how long to wait before stopping heading output, using the Omnipad.
10. Press the [ENT] key followed by the [DISP] key to close the menu.

3.12 TRIP Menu

The TRIP menu functions to

- Choose the indication to show on the speed display
- Choose source of distance run
- Reset distance run to zero
- Smooth the tide drift indication
- Enter rate of turn (see the next page)

1. Press the [MENU] key to display the main menu.
2. Choose TRIP MENU and then press the [ENT] key.

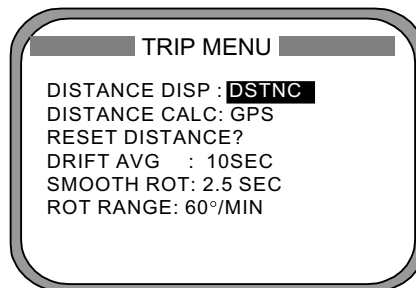

TRIP menu

3. Choose DISTANCE DISP and then press the [ENT] key.
4. Choose what to display on the Speed display; distance run (DSTNC) or tide direction and speed (DRIFT). Press the [ENT] key.
5. Choose DISTANCE CALC and then press the [ENT] key.
6. Choose the source for distance run; GPS, VLW (distance traveled through water) or VBW (Dual ground/water speed). (VLW requires DS-80 type Doppler speed log and VBW requires Current indicator or Doppler speed log.) Press the [ENT] key.
7. Choose DRIFT AVG. and then press the [ENT] key.
8. If tide current and speed data is unstable, enter a smoothing figure to stabilize the data. The higher the figure the more smoothed the data. A setting between 0 (no smoothing) and 9999 is available.
9. Choose SMOOTH ROT and then press the [ENT] key.
10. Use the Omnipad to enter rate of turn smoothing rate. Choose location with ◀ or ▶; change value with ▲ or ▼.
11. Press the [ENT] key.
12. Choose ROT RANGE and then press the [ENT] key.
13. Choose the range of the ROT graph from among 30, 60 and 90 and then press the [ENT] key.
14. Press the [DISP] key to close the menu.

3.13 Resetting Distance Run

The distance run may be reset to zero as below when the source of distance run is GPS or VBW.

1. Press the [MENU] key to display the main menu.
2. Choose TRIP MENU and then press the [ENT] key.
3. Choose RESET DISTANCE and then press the [ENT] key.

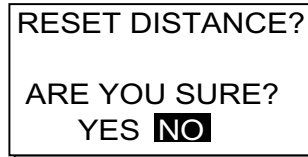

RESET DISTANCE prompt

4. Choose YES and then press the [ENT] key.
5. Press the [DISP] key to close the menu.

3. OPERATION

(This page intentionally left blank.)

4 MAINTENANCE, TROUBLESHOOTING

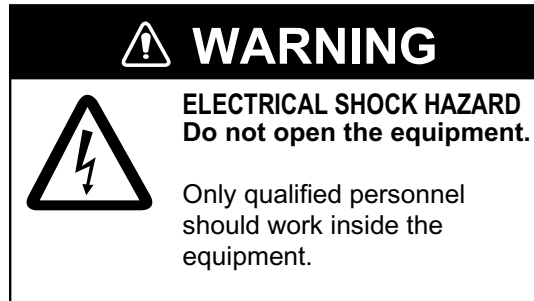

4.1 Preventive Maintenance

Regular maintenance is important for good performance. A maintenance program should be established and should include the following points.

- Check connectors and ground terminal on the processor unit and display unit for tightness.
- Check ground terminal for rust. Clean or replace as necessary.
- Check for water leakage in the antenna cable. Replace the cable if there are signs of water leakage.
- Remove dust and dirt from the display unit (including LCD) and processor unit with a dry, soft cloth. Wipe the LCD carefully to prevent scratching, using tissue paper and an LCD cleaner. To remove stubborn dirt, use an LCD cleaner, wiping slowly with tissue paper so as to dissolve the dirt. Change paper frequently so the dirt will not scratch the LCD. Do not use chemical cleaners for cleaning - they can remove paint and markings.

4.2 Troubleshooting

This section provides basic troubleshooting procedures which the user may follow to restore normal operation.

Troubleshooting

Symptom	Cause	Remedy
Cannot turn on the power.	Power connector on the processor unit	Firmly connect the power connector.
	Power supply failure	Check the power supply.
	Blown fuse	Have a qualified technician check the fuse.
Heading indication changes randomly when ship is at anchor or does not change when ship moves.	Sensor trouble	Run the diagnostic test ² to determine cause.
Heading output from SC-50 does not appear on external equipment.	Connection between SC-50 and external equipment has loosened.	Firmly fasten the connector.
	Sensor trouble	Run the diagnostic test ¹ to determine the cause.

If large heading error occurs or heading indication is frequently interrupted, contact your dealer for advice.

4.3 Diagnostics

Diagnostic test1

The diagnostic test1 checks the equipment for proper operation.

Note: Heading is not output during the diagnostic test, and this is communicated with an appropriate message. After completing the diagnostic test, turn the power off and on to update heading data.

1. Press the [MENU] key to open the menu.
2. Choose SYS SETUP and then press the [ENT] key.
3. Choose TEST? and then press the [ENT] key.

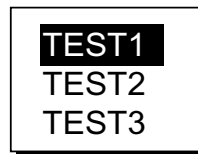

Test menu options

4. Confirm that TEST1 is selected and then press the [ENT] key.

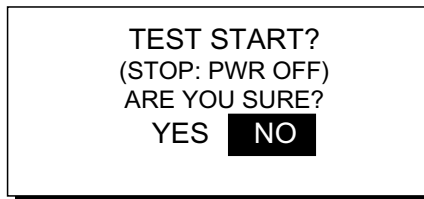

Test start prompt

5. Press ◀ to choose YES and then press the [ENT] key. The test proceeds in the sequence shown on the next page.

4. MAINTENANCE, TROUBLESHOOTING

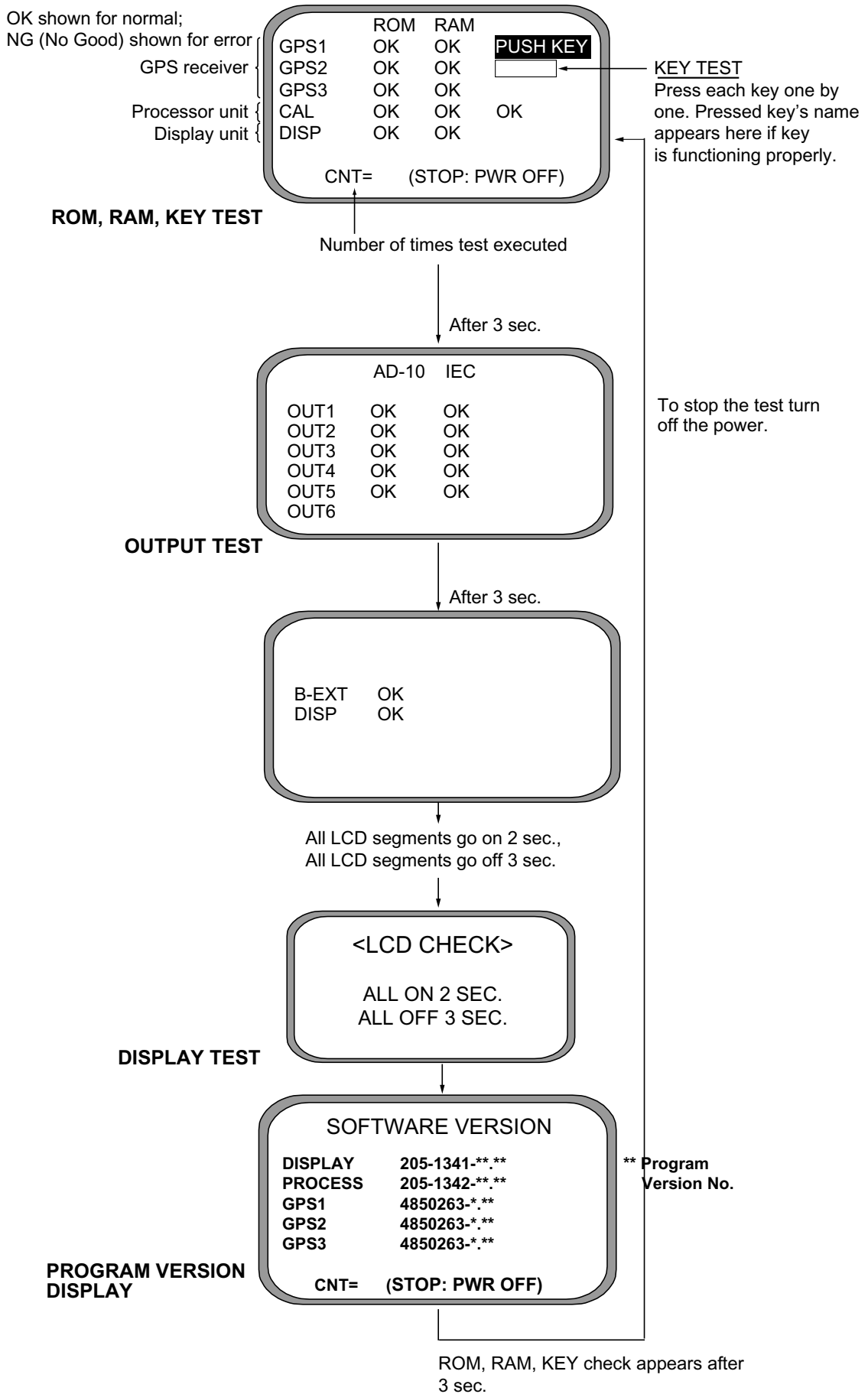

Diagnostic test sequence

6. Turn off the processor unit to quit the diagnostic test1.

Diagnostic test2

If the heading indication changes randomly when ship is at anchor or does not change when the ship moves, run the test2 following the procedure below, with the ship at anchor and satellite signal received.

Note: Heading is not output during the diagnostic test, and this is communicated with an appropriate message. After completing the diagnostic test, turn the power off and on to update heading data.

1. Press the [MENU] key to open the menu.
2. Choose SYS SETUP and then press the [ENT] key.
3. Choose TEST? and then press the [ENT] key.

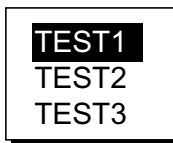

Test menu options

4. Choose TEST2 and then press the [ENT] key.

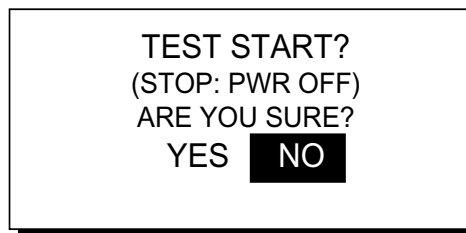

Test start prompt

5. Press ◀ to choose YES and then press the [ENT] key.
6. Press the [ENT] key twice. Rate and angle values are 0.0°. If the values increase or decrease markedly (with ship at anchor), suspect rate sensor trouble. Contact your dealer to request service.

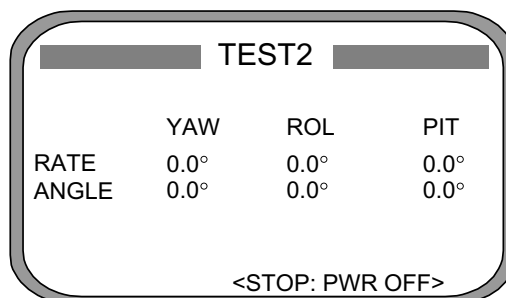

TEST2 display

7. Turn off the processor unit to quit the diagnostic test2.

Diagnostic test3

This test checks the buzzer signal/contact for proper operation.

1. Press the [MENU] key to open the menu.
2. Choose SYS SETUP and then press the [ENT] key.
3. Choose TEST? and then press the [ENT] key.

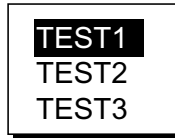

Test menu options

4. Choose TEST3 and then press the [ENT] key.

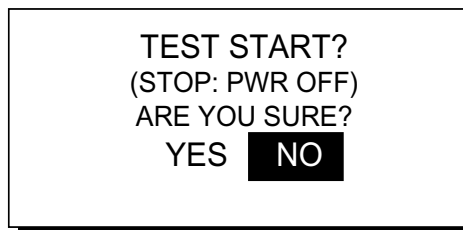

Test start prompt

6. Press ◀ to choose YES and then press the [ENT] key.

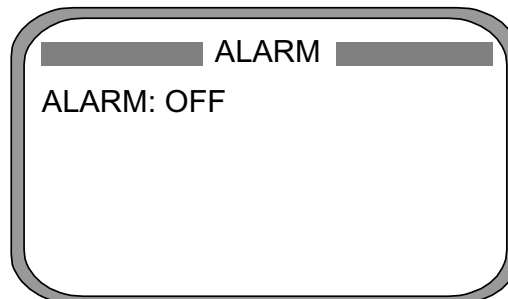

ALARM menu

7. Press the [ENT] key.

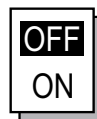

ALARM options

8. Choose OFF or ON as appropriate and then press the [ENT] key.
OFF: Buzzer sound goes off, alarm contact signal is closed, and alarm sounds continuously.
ON: The buzzer sounds and the alarm contact is open.
9. To quit the test, turn off the processor unit.

4.4 Program Number

You may display the program number as follows:

1. Press the [MENU] key to open the menu.
2. Choose SOFT VER. and then press the [ENT] key.

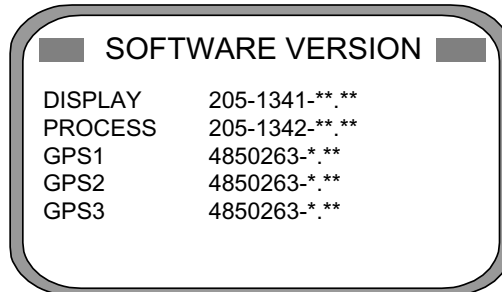

** = Program version no.

Program version no. display

3. Press the [DISP] key to close the program version no. display.

4.5 Clearing Data

You may clear GPS data and system data all at once or individually as follows:

1. Press the [MENU] key to open the menu.
2. Choose ERASE and then press the [ENT] key.
3. Choose GPS DATA, SYSTEM DATA or ALL BACKUP DATA (clears GPS and SYSTEM data) as appropriate. One of the following displays appears depending on your selection.

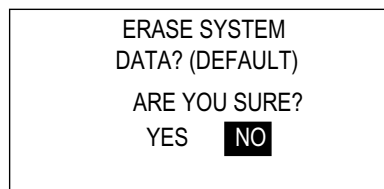
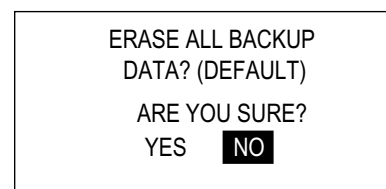
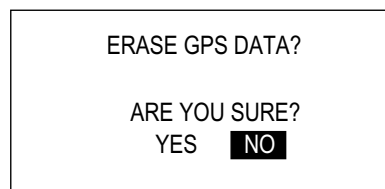

Prompts for erasure of data

4. Press ◀ to choose YES and then press the [ENT] key to erase. After data is erased the message "Completed erasing. Turn off the unit." is displayed.

Note: MOUNTING, DIRECTION and LANGUAGE in the INST menu, HDG RESTORATION and HDG BACKUP in the OTHERS menu and OFFSET in the HEADING SETUP menu are not cleared.

5. Turn off and on the power.

4.6 Replacement of Battery

The processor unit has a battery which stores data when the power is turned off. When the battery voltage is low, the message "BATTERY!" appears on the display. Have a qualified technician replace the battery, following the procedure below. The life of the battery is 3-5 years.

Battery Location	Type	Code No.
Processor Unit	CR2450-F2ST2	000-133-495

1. Press the [MENU] key to open the menu.
2. Choose SYS SETUP and then press the [ENT] key.
3. Choose "EXCHANGE BATTERY?" and then press the [ENT] key.

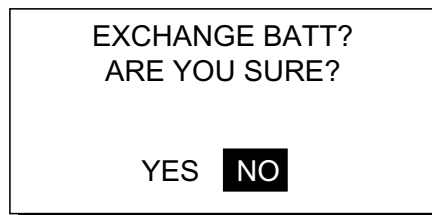

Prompt for exchanging battery

4. Press ◀ to choose YES and then press the [ENT] key. The following message appears.

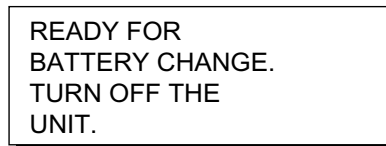

Prompt for turning off the power

5. At this time the contents of the RAM are temporarily moved to the flash memory. Turn off the power.
6. Have a qualified technician replace the battery.

4.7 Replacement of Fuse

The 3 A fuse on the POWER Board inside the processor unit protects the equipment from overcurrent and reverse polarity of the power supply. If the fuse blows, have a qualified technician check the fuse.



4.8 Error Messages

The alarm sounds for equipment error and is accompanied by a flashing exclamation mark (⚠). Press any key to silence the alarm. The exclamation mark remains on the screen until the cause for error is eliminated. Find the cause for the alarm(s) as follows:

1. Press the [MENU] key to open the menu.
2. Choose MESSAGES and then press the [ENT] key.

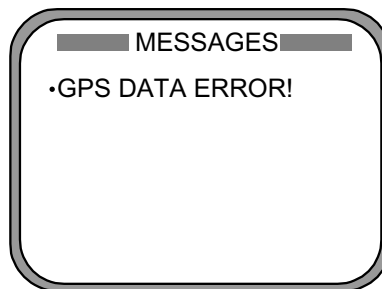

Message display

3. Press the [DISP] key to close the menu.

Error messages

Error Message	Meaning	Remedy
ABORTING!	GPS heading error continues for one minute. For example, satellite cannot be acquired because of unfavorable environment.	Check for obstruction.
ABORTING CALC!	GPS signal lost for one minute.	Press any key to try to restore normal operation.
BACKUP ERROR!(DISP)	Corrupted backup data found in display unit at power on.	Default settings are automatically restored.
BACKUP ERROR!(PRCSSR)	Corrupted backup data found at processor unit at power on.	Default settings are automatically restored.

(Continued on next page)

4. MAINTENANCE, TROUBLESHOOTING

Error messages (con't from previous page)

Error Message	Meaning	Remedy
BATTERY ALM!	Voltage of battery in processor unit is low.	Have battery replaced at earliest convenience.
DATA ERR!	GPS data (from the GPS receiver in the processor unit) is lost for one minute. Heading output is stopped and the heading indication shows " - - -".	Check navigator.
DGPS ERROR!	DGPS data (from external DGPS receiver) is lost for one minute.	Ship may not be within DPGS service area.
GPS DATA ERROR!	GPS data (from internal GPS receiver) is lost for one minute. Heading output is stopped and the heading indication shows " - - -".	Conduct diagnostic test ¹ and check if NG appears for results for GPS receivers GPS1, GPS2 and GPS3.
GPS NO FIX!	No GPS data.	Check antenna cable.
HDG ERROR!	Heading error	Request service.
NO HEADING OUTPUT!	GPS heading error continues for five minutes. In this case heading output is stopped and the heading indication shows " - - -".	Press any key to try to restore normal operation.
RAM ERROR!	RAM problem	Request service.
RATE ERROR!	Data output stopped.	Request service.
RATE ERROR(YAW)!	Yaw sensor problem	Request service.
RATE ERROR(ROLL)!	Roll sensor problem	Request service.
RATE ERROR(PITCH)!	Pitch sensor problem	Request service.
COMMUNICATION ERR!	Communication between display unit and processor has been interrupted.	Request service.
WAAS ERROR	WAAS data lost for one minute.	Request service.
ROM ERROR!	ROM problem	Request service.

APPENDIX

Menu Tree

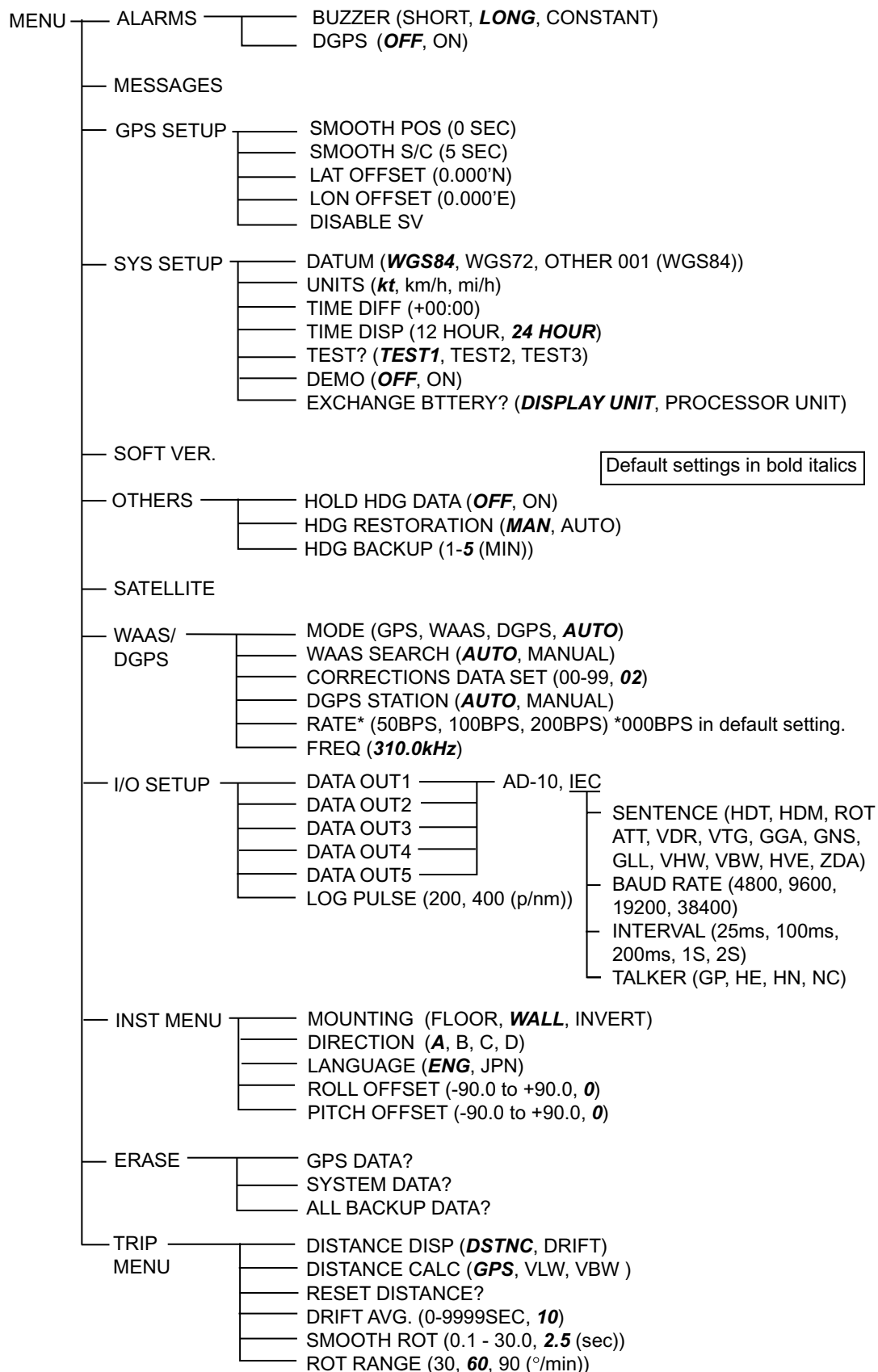

APPENDIX

(This page intentionally left blank.)

**SPECIFICATIONS OF SATELLITE COMPASS
SC-50**

SPECIFICATIONS

1 GENERAL

- 1.1 Receiver Type 12 discrete channels
- 1.2 Rx Frequency 1575.42 MHz
- 1.3 Rx Code C/A code, WAAS
- 1.4 Position Fixing System All-in-view, 8-state Kalman filter
- 1.5 Position Accuracy 10 m, or 5 m (DGPS), 95% of the time
- 1.6 Heading Accuracy $\pm 1.0^\circ$ (95%)
- 1.7 Follow-up 45°/s rate-of-turn
- 1.8 Settling Time 3 minutes

2 DISPLAY UNIT

- 2.1 Display Type 4.5 inch monochrome LCD, 120 x 64 dots
- 2.2 Effective Area 60 mm (H) x 95 mm (W)
- 2.3 Contrast 64 levels
- 2.4 Display Mode Heading, Nav data, Steering, Compass rose, Rate of turn and Speed modes

3 INTERFACE

3.1 Output

Data	No. of Ports, Format	Sentence, Remarks
Heading	One AD-10, Five AD-10/IEC 61161-1/2	HDM, HDT
COG		VHW, VBW,
SOG		VHW, VBW, VTG
ROT		ROT
L/L		GLL, GNS, GGA
Set and Drift		VDR
Heading Alarm	One contact signal	
Log Pulse	One contact signal	
Analog pitch/roll		FURUNO Proprietary sentence ATT

3.2 Input

Data	No. of Ports, Format	Sentence, Remarks
External Heading Data	One AD-10/IEC 61162-1/2	HDT, HDG, HDM
External DGPS	One RTCM SC-104	

4 POWER SUPPLY

12-24 VDC: 1.2-0.5 A

5 ENVIRONMENTAL CONDITIONS AND EMC

5.1 Ambient Temperature

Display/Processor Unit -15°C to +55°C, Designed for protected area

Antenna Unit -25°C to +70°C, Designed for exposed area

5.2 Damp Heat 93% ±3% at 40°C

5.3 Waterproofing

Antenna Unit IPX6

Display Unit IPX5

Processor Unit IPX0

5.4 Vibration IEC 60945

5.5 EMC IEC 60945

6 COATING COLOR

6.1 Display/Processor Unit Panel: N3.0 Newtone No.5 (dark gray)
Cover: 2.5GY5/1.5 (light gray)

6.2 Antenna Unit N9.5 (white)



INDEX

A		
Alarms menu	3-6	
B		
Battery replacement	4-8	
C		
Compass display	3-4	
Control description	3-1	
D		
Data clearing	4-7	
Demonstration mode	3-15	
DGPS alarms	3-6	
Diagnostics		
test 1	4-3	
test 2	4-5	
test 3	4-6	
DIM key	3-2	
DISP key	3-3	
Distance run display	3-4, 3-5	
Distance run resetting	3-21	
E		
Error messages	4-9	
F		
Fuse replacement	4-9	
G		
Geodetic data	3-13	
GPS setup menu	3-8	
H		
Heading		
backup	3-19	
output	3-9	
restoration	3-19	
Heading display	3-3	
L		
Local time	3-14	
Log pulse	3-12	
M		
Maintenance		
battery replacement	4-8	
cleaning	4-1	
fuse replacement	4-9	
Menu tree	1	
N		
Nav data display	3-3	
O		
OTHERS menu	3-19	
Output data setup menu	3-9	
P		
Position offset	3-8	
Power on/off	3-2	
Program version no.	4-7	
R		
Rate-of-turn display	3-4	
ROT range, smoothing	3-20	
S		
SAT STATUS key	3-1	
Satellite status display	3-7	
Satellites		
disabling	3-9	
status display	3-7	
Set and drift display	3-5	
Smoothing	3-8	
Steering display	3-4	
System configuration	v	
System setup menu	3-13	
T		
Time format	3-14	
TRIP menu	3-20	
Troubleshooting	4-2	
U		
Units of measurement	3-14	
W		
WAAS/DGPS menu	3-16	

PACKING LIST

20AY-X-9851 -0 1/1

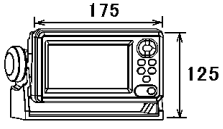
SC-502-J/E

NAME	OUTLINE	DESCRIPTION/CODE	Q'TY
ユニット UNIT			
表示部 DISPLAY UNIT		SC-502-J 000-041-906 **	1
工事材料 INSTALLATION MATERIALS			
工事材料 INSTALLATION MATERIALS		CP20-02203 004-380-660	1

1.コード番号末尾の[**]は、選択品の代表型式/コードを表します。
CODE NUMBER ENDED BY "**" INDICATES THE NUMBER OF TYPICAL MATERIAL.



(略図の寸法は、参考値です。 DIMENSIONS IN DRAWING FOR REFERENCE ONLY.)

20AY-X-9851

PACKING LIST

20AY-X-9852 -0 1/1

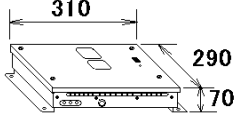
SC-501-J/E

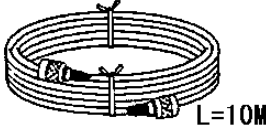
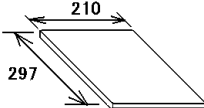
NAME	OUTLINE	DESCRIPTION/CODE	Q'TY
ユニット UNIT			
演算部 PROCESSOR UNIT		SC-501 000-041-903	1
予備品 SPARE PARTS			
予備品 SPARE PARTS		SP20-00901 004-377-600	1
工事材料 INSTALLATION MATERIALS			
工事材料 INSTALLATION MATERIALS		CP20-02601 004-380-560	1
その他工材 OTHER INSTALLATION MATERIALS			
ケーブル組品MJ CABLE ASSY.		MJ-A7SPF0006-100 000-143-578	1
図書 DOCUMENT			
取扱説明書(和) OPERATOR'S MANUAL		OMJ-72510-* 000-148-547 **	1

コード番号末尾の[**]は、選択品の代表型式/コードを表します。
CODE NUMBER ENDED BY "**" INDICATES THE NUMBER OF TYPICAL MATERIAL.



(略図の寸法は、参考値です。 DIMENSIONS IN DRAWING FOR REFERENCE ONLY.)

20AY-X-9852

PACKING LIST

20AY-X-9854 -0 1/1

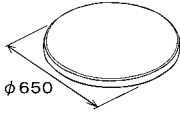
SC-303

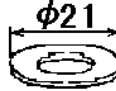
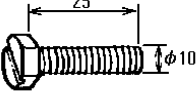
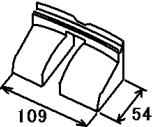
NAME	OUTLINE	DESCRIPTION/CODE	Q'TY
ユニット UNIT			
GPSアンテナ GPS ANTENNA		SC-303 000-041-925	1
工事材料 INSTALLATION MATERIALS CP20-02231			
ハネ座金 SPRING WASHER		M10 SUS304 000-864-261	4
ミカキ平座金 FLAT WASHER		M10 SUS304 000-864-131	4
六角ボルト 刃割 HEX. BOLT (SLOTTED HEAD)		M10X25 SUS304 000-862-308	4
ケーブルカバー CABLE COVER		20-020-3213-1 100-291-511	1

(略図の寸法は、参考値です。 DIMENSIONS IN DRAWING FOR REFERENCE ONLY.)

20AY-X-9854

FURUNO

CODE NO.	004-380-660	20AY-X-9404 -0 1/1
TYPE	CP20-02203	

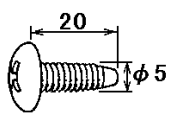
工事材料表 INSTALLATION MATERIALS					
番号 NO.	名称 NAME	略図 OUTLINE	型名/規格 DESCRIPTIONS	数量 Q'TY	用途/備考 REMARKS
1	+トラスタツピ [®] ソネジ [®] +TAPPING SCREW		5X20 SUS304 1ｼ1	4	
	CODE NO.		000-802-081		

20AY-X-9404

(略図の寸法は、参考値です。 DIMENSIONS IN DRAWING FOR REFERENCE ONLY.)

FURUNO ELECTRIC CO., LTD.

FURUNO

CODE NO.	004-380-560	20AY-X-9401 -0 1/1
TYPE	CP20-02601	

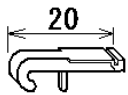
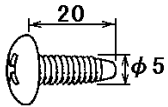
工事材料表 INSTALLATION MATERIALS					
番号 NO.	名称 NAME	略図 OUTLINE	型名/規格 DESCRIPTIONS	数量 Q'TY	用途/備考 REMARKS
1	操作レバー TERMINAL OPENER		231-131	2	
			CODE NO.		
2	+トラスタップンネジ +TAPPING SCREW		5X20 SUS304 1ヶ	4	
			CODE NO.		



20AY-X-9401

(略図の寸法は、参考値です。 DIMENSIONS IN DRAWING FOR REFERENCE ONLY.)

FURUNO ELECTRIC CO., LTD.

FURUNO

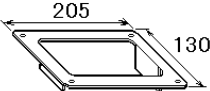
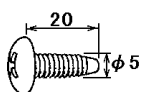
CODE NO.	000-041-405	20AY-X-9402 -0 1/1
TYPE	OP20-29	

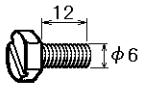
フラッシュマウントキット FLUSH MOUNT KIT.					
番号 NO.	名称 NAME	略図 OUTLINE	型名 / 規格 DESCRIPTIONS	数量 Q'TY	用途 / 備考 REMARKS
1	化粧パネル COSMETIC PANEL		20-016-1051-0	1	
			CODE NO. 100-251-370		
2	+トラスタップネジ TAPPING SCREW		5X20 SUS304 1種 4	4	
			CODE NO. 000-802-840		
3	パネル座金 SPRING WASHER		M6 SUS304	2	
			CODE NO. 000-864-260		
4	六角ボルト スリ割り HEX. BOLT (SLOTTED HEAD)		M6X12 SUS304	2	
			CODE NO. 000-862-127		

20AY-X-9402

FURUNO ELECTRIC CO., LTD.
(略図の寸法は、参考値です。 DIMENSIONS IN DRAWING FOR REFERENCE ONLY.)

FURUNO

CODE NO.	000-040-720	20AY-X-9403 -0 1/1
TYPE	OP20-17	

フラッシュマウントキット FLUSH MOUNT KIT.					
番号 NO.	名称 NAME	略図 OUTLINE	型名 / 規格 DESCRIPTIONS	数量 Q'TY	用途 / 備考 REMARKS
1	フラッシュマウント FIXING PLATE FOR FLUSH MOUNT		20-007-2401-0	2	
			CODE NO. 100-183-190		
2	蝶ナット WING NUT		M4 YBSC2 MBN12	4	
			CODE NO. 000-863-306		
3	蝶ボルト WING SCREW		M4X30 YBSC2 MBN12	4	
			CODE NO. 000-804-799		
4	バネ座金 SPRING WASHER		M6 SUS304	2	
			CODE NO. 000-864-260		
5	六角ボルト スリ割り HEX. BOLT (SLOTTED HEAD)		M6X12 SUS304	2	
			CODE NO. 000-862-127		

20AY-X-9403

FURUNO ELECTRIC CO., LTD.
(略図の寸法は、参考値です。 DIMENSIONS IN DRAWING FOR REFERENCE ONLY.)

FURUNO

CODE NO.		20AT-X-9403 -1
TYPE		1/1

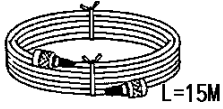
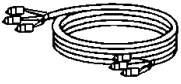
工事材料表 INSTALLATION MATERIALS		SC-50/55/60			
番号 NO.	名称 NAME	略図 OUTLINE	型名/規格 DESCRIPTIONS	数量 Q'TY	用途/備考 REMARKS
1	ケーブル組品 ANTENNA CABLE ASSY.	 L=15M	TNC-PS-3D-15 20S0216	3	選択 TO BE SELECTED
			CODE NO.		
2	ケーブル組品 CABLE ASSY.	 L=15M	TPPX6-3D2V-15M	1	選択 TO BE SELECTED
			CODE NO.		

20AT-X-9403

(略図の寸法は、参考値です。 DIMENSIONS IN DRAWING FOR REFERENCE ONLY.)

FURUNO ELECTRIC CO., LTD.

FURUNO

CODE NO.	004-379-660	20AT-X-9410 -0 1/1
TYPE	CP20-02260	

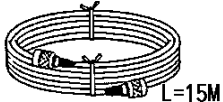
工事材料表 INSTALLATION MATERIALS					
番号 NO.	名称 NAME	略図 OUTLINE	型名/規格 DESCRIPTIONS	数量 Q'TY	用途/備考 REMARKS
1	ケーブル組品 ANTENNA CABLE ASSY.		TNC-PS-3D-15 20S0216 CODE NO. 000-133-670	3	

20AT-X-9410

FURUNO ELECTRIC CO., LTD.
 (略図の寸法は、参考値です。 DIMENSIONS IN DRAWING FOR REFERENCE ONLY.)

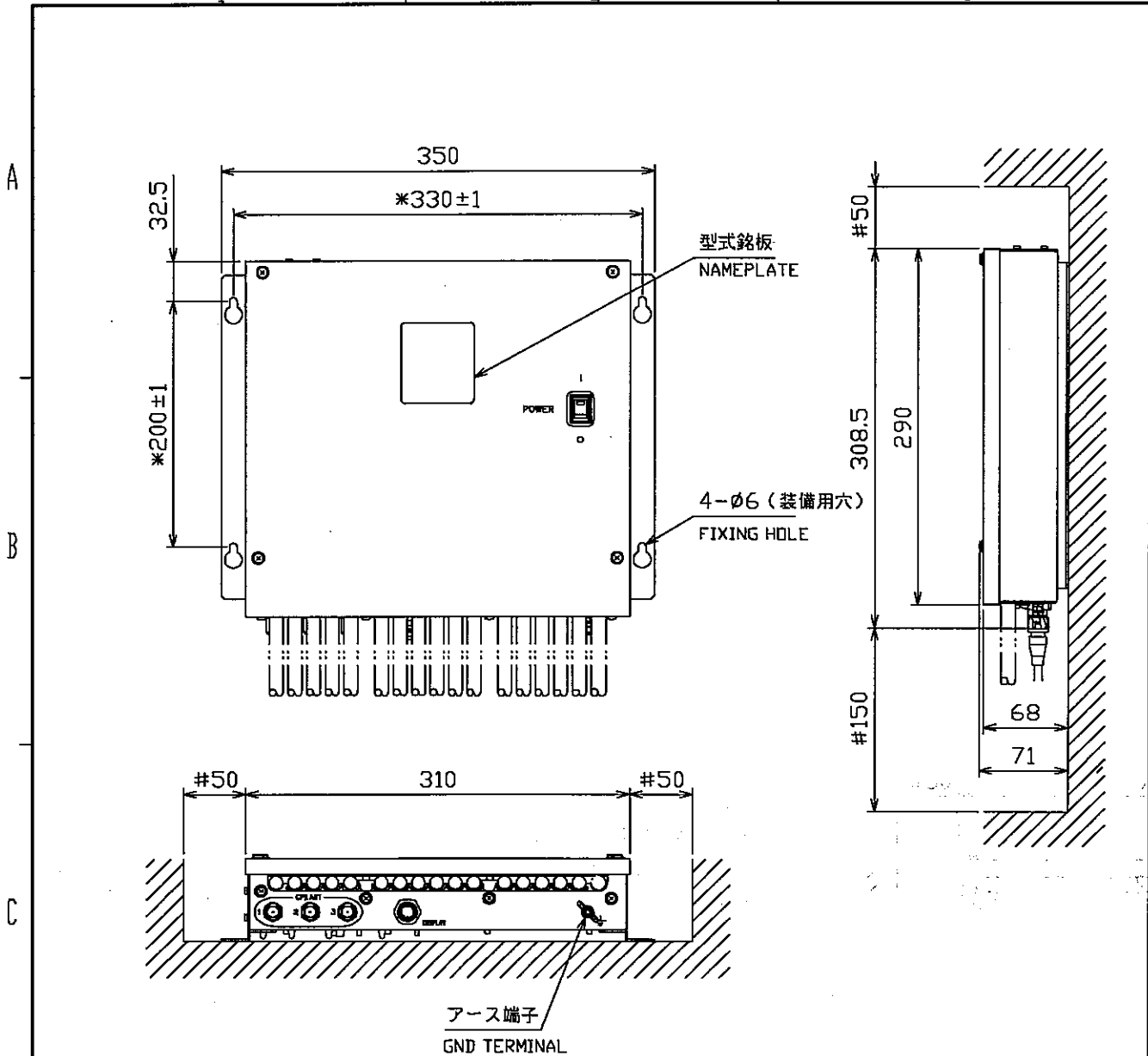

注 記

- 1) 装備ケーブルはサービス時、本体を前方に十分引き出せるよう余裕を持たせること。
- 2) 取付用ネジはトラスタップネジ呼び径5×20を使用のこと。
- 3) 指定外寸法公差は表1による。
- 4) 印寸法は最小サービス空間寸法とする。

NOTE

1. KEEP SUFFICIENT CABLE LENGTH BEHIND THE UNIT FOR MAINTENANCE, WHICH IS NOT SPECIFIED.
2. USE TAPPING SCREWS 5x20 FOR FIXING THE UNIT.
3. TABLE 1 INDICATES TOLERANCE OF DIMENSIONS.
4. #: RECOMMENDED SERVICE CLEARANCE.

寸法区分 (mm) DIMENSION	公差 (mm) TOLERANCE
$0 < L \leq 50$	± 1.5
$50 < L \leq 100$	± 2.5
$100 < L \leq 500$	± 3

表 1 TABLE 1

DRAWN July, 31 2003. H. MAKI		TITLE SC-501/1101
CHECKED		名称 演算部
APPROVED	SC-50/110	外寸図
SCALE 1/5	MASS 4.0 $\pm 10\%$ kg	NAME PROCESSOR UNIT
DWG.No. C7251-G01-A	20-024-100G-2	OUTLINE DRAWING

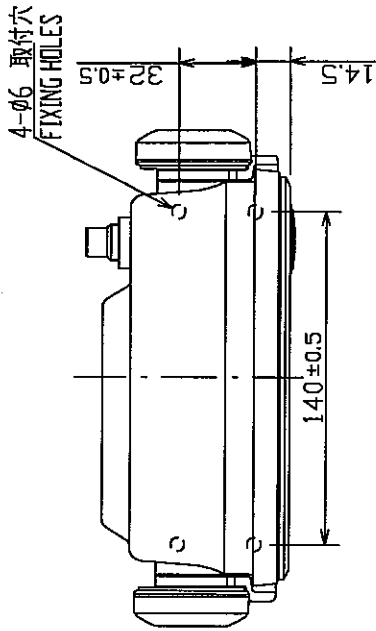

寸法区分 (mm) DIMENSION	公差 (mm) TOLERANCE
0 < L ≤ 50	±1.5
50 < L ≤ 100	±2.5
100 < L ≤ 500	±3

表 1 TABLE 1

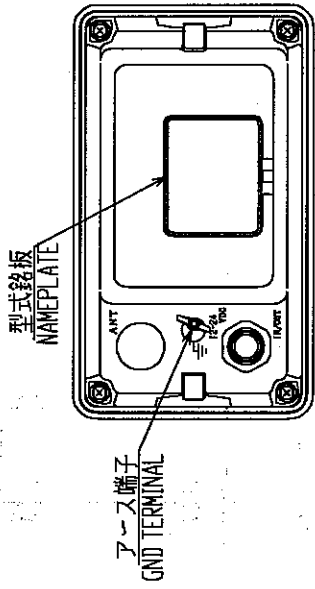

矢視 A VIEW A

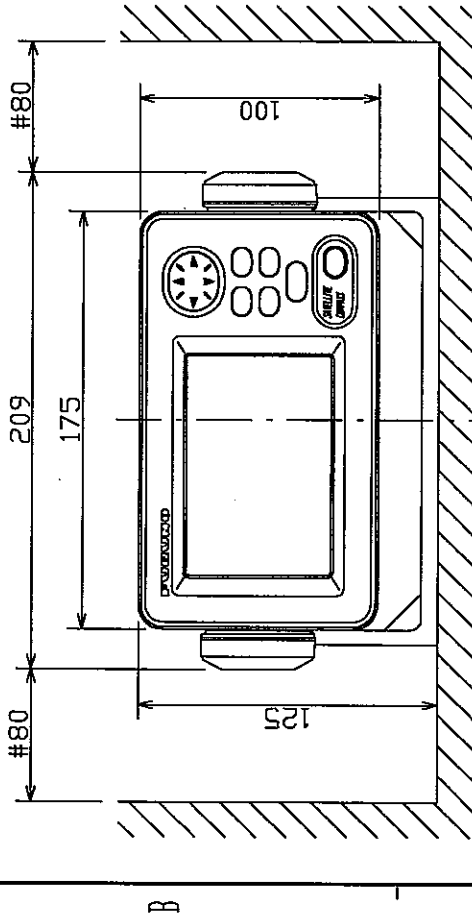
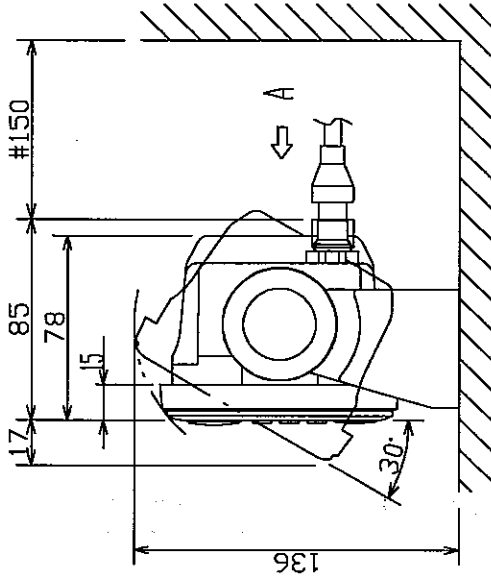

- 注 記
- 1) 装備ケーブルはサービス時、本体を前方に十分引き出せるよう余裕を持たせること。
 - 2) 取付用ネジはトラスタツピンネジ呼び径5×20を使用すること。
 - 3) 指定外寸法公差は表 1 による。
 - 4) #印寸法は最小サービス空間寸法とする。

NOTE

1. KEEP SUFFICIENT CABLE LENGTH BEHIND THE UNIT FOR MAINTENANCE.
2. USE TAPPING SCREWS 5x20 FOR FIXING THE UNIT.
3. TABLE 1 INDICATES TOLERANCE OF DIMENSIONS.
4. # RECOMMENDED SERVICE CLEARANCE.

DESIGN CHECKED	H. MAKI	MODEL	SC-50/110	TITLE	SC-602/502
APPROVED		CHECKED	SC-60/20/55	名称	表示部 (卓上装備)
SCALE	1/3	FOR MASS	0.55 kg	外寸図	
DWG. No.	C7248-G02-G			NAME	DISPLAY UNIT (DESKTOP MOUNT)
					OUTLINE DRAWING
					20-019-2000-G0

寸法区分 (mm) DIMENSION	公差 (mm) TOLERANCE
0 < L ≤ 50	±1.5
50 < L ≤ 100	±2.5
100 < L ≤ 500	±3
500 < L ≤ 1000	±4

表 1 TABLE 1

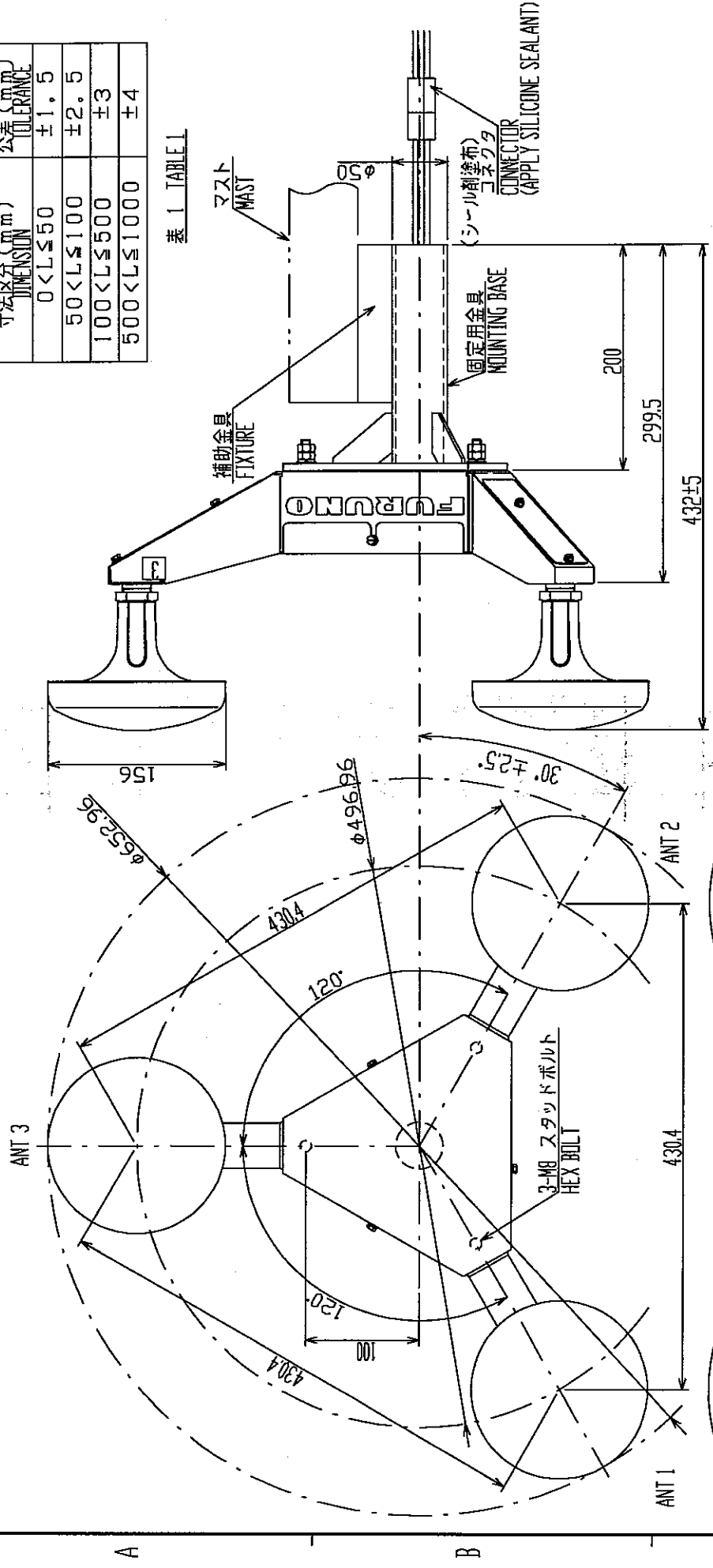

NOTE

- 注 記:
- 1) 指定外の寸法公差は表 1 による。
 - 2) 取付は溶接にてしっかりと固定のこと。

注 記:

- NOTE
1. TABLE 1 INDICATES TOLERANCE OF DIMENSIONS.
 2. FIX THE UNIT SECURELY BY WELDING.

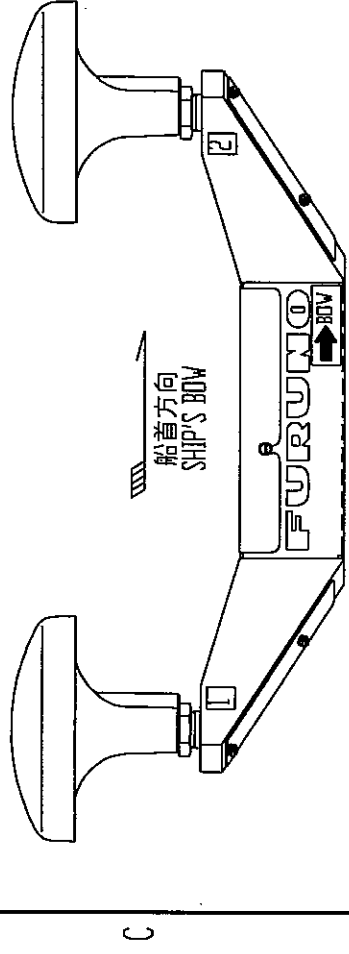

DRAWING NO.	SC-603
CHECKED	空無線部
APPROVED	外寸図
SCALE	1/5
DWG. No.	C7248-005-B
TITLE	SC-603
NAME	ANTENNA UNIT
DATE	20-019-3100-00
DESCRIPTION	OUTLINE DRAWING

寸法区分(mm) DIMENSION	公差(mm) TOLERANCE
0 < L ≤ 50	±1.5
50 < L ≤ 100	±2.5
100 < L ≤ 500	±3
500 < L ≤ 1000	±4

表1 TABLE1

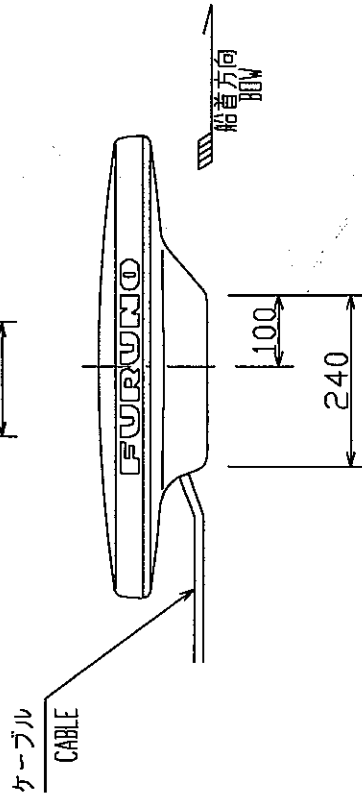
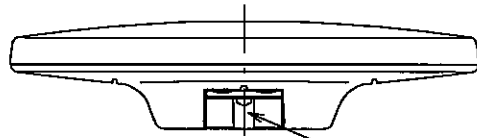
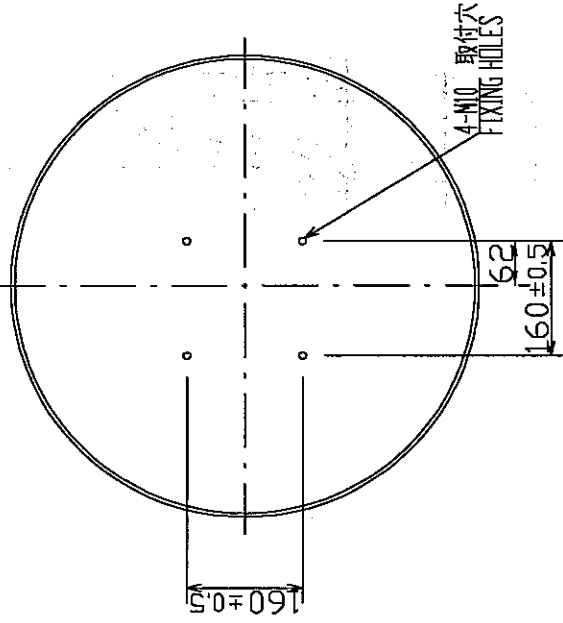
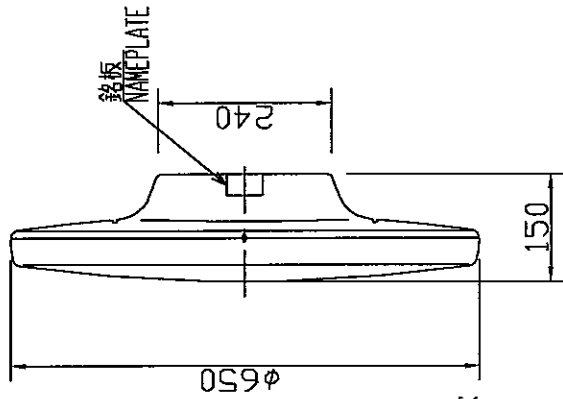

注記 1) 指定外の寸法公差は表1による。
2) 取付用ネジはM10ボルトを使用のこと。

NOTE 1. TABLE 1 INDICATES TOLERANCE OF DIMENSIONS.
2. USE M10 BOLTS FOR FIXING THE UNIT.

DRAWN 2003 May	H. MAKI	TITLE	SC-303/503
CHECKED		名称	空中線部
APPROVED		外寸図	
SCALE	1/10	NAME	ANTENNA UNIT
DWG.No.	C7248-606-C		OUTLINE DRAWING
			20-020-300G-1

